

Orchard Avenue Between Muir St and Thomas Ave

Summary Comparison 2023 vs. 2025

2023 Data Collection: 1/31/2023 to 2/2/2023

2025 Data Collection: 1/28/2023 to 2/3/2025

Volume	2023	2025	% Difference
EB (Avg)	5557	5638	1.5%
WB (Avg)	6650	6675	0.4%
Total (Avg)	12206	12313	0.9%

Speed	2023	2025	% Difference
EB (50th percentile)	25.2	24.2	-4.0%
EB (85th percentile)	29.3	28.3	-3.4%
EB (95th percentile)	32.1	31.1	-3.1%
EB (Average)	25.2	24.2	-4.0%
EB 10 mph Pace	20.5 - 30.5	19.1 - 29.1	
Percent in Pace	78.9%	78.7%	

WB (50th percentile)	24.2	23.2	-4.1%
WB (85th percentile)	28.6	27.1	-5.2%
WB (95th percentile)	31.8	29.5	-7.2%
WB (Average)	24.3	23.1	-4.9%
WB 10 mph Pace	19.2 - 29.2	18.3 - 28.3	
Percent in Pace	76.2%	80.2%	

Vehicle Class (EB)	2023	2025	% Difference
EB Class 1-3	15839	16142	1.9%
EB Class 4-13	831	335	-59.7%
WB Class 1-3	18955	18994	0.2%
WB Class 4-13	994	394	-60.4%
Total Class 1-3	34794	35136	1.0%
Total Class 4-13	1825	729	-60.1%

Class 1 - Motorcycles

Class 2 - Passenger Cars

Class 3 - Other two axle, four-tire

Class 4 - Busses

Class 5 - Two-axle, six-tire, single-unit trucks

Class 6 - Three-axle, single-unit trucks

Class 7 - Four or more axle, single-unit trucks

Class 8 - Four or fewer axle, single-trailer trucks

Class 9 - Five-Axle, single-trailer trucks

Class 10 - Six or more axle, single-trailer trucks

Class 11 - Five or fewer axle, multi-trailer trucks

Class 12 - Six-axle, multi-trailer trucks

Class 13 - Seven or more axle, multi-trailor trucks

Orchard Avenue Between Oneil Ave to Joyce St

Summary Comparison 2023 vs. 2025

2023 Data Collection: 1/31/2023 to 2/2/2023

2025 Data Collection: 1/28/2023 to 2/3/2025

Volume	2023	2025	% Difference
EB (Avg)	5677	5638	-0.7%
WB (Avg)	6641	6675	0.5%
Total (Avg)	12319	12313	0.0%

Speed	2023	2025	% Difference
EB (50th percentile)	35.7	32.9	-7.8%
EB (85th percentile)	41.2	38.5	-6.6%
EB (95th percentile)	45	42.2	-6.2%
EB (Average)	35.8	33	-7.8%
EB 10 mph Pace	30.5 - 40.5	27.8 - 37.8	
Percent in Pace	67.2%	66.0%	

WB (50th percentile)	37.1	35.2	-5.1%
WB (85th percentile)	42.2	39.9	-5.5%
WB (95th percentile)	46	43.2	-6.1%
WB (Average)	37.1	35.3	-4.9%
WB 10 mph Pace	32.4 - 42.4	30.4 - 40.4	
Percent in Pace	69.0%	73.3%	

Vehicle Class (EB)	2023	2025	% Difference
EB Class 1-3	16134	16535	2.5%
EB Class 4-13	898	379	-57.8%
WB Class 1-3	19304	19616	1.6%
WB Class 4-13	620	409	-34.0%
Total Class 1-3	35438	36151	2.0%
Total Class 4-13	1518	788	-48.1%

Class 1 - Motorcycles

Class 2 - Passenger Cars

Class 3 - Other two axle, four-tire

Class 4 - Busses

Class 5 - Two-axle, six-tire, single-unit trucks

Class 6 - Three-axle, single-unit trucks

Class 7 - Four or more axle, single-unit trucks

Class 8 - Four or fewer axle, single-trailer trucks

Class 9 - Five-Axle, single-trailer trucks

Class 10 - Six or more axle, single-trailer trucks

Class 11 - Five or fewer axle, multi-trailer trucks

Class 12 - Six-axle, multi-trailer trucks

Class 13 - Seven or more axle, multi-trailor trucks

Mission Blvd/Orchard Avenue/Carlos Bee Blvd

Summary Comparison 2023 vs. 2025

AM Peak Hour

2023 Data Collection: 2/15/2023

2023 Peak Hour: 7:30 - 8:30

2025 Data Collection: 1/29/2025

2025 Peak Hour: 7:30 - 8:30

Volume (Vehicles)	2023	2025	% Difference
EB U-Turn	0	0	0.0%
EB Left Turn	154	145	-5.8%
EB Through	213	207	-2.8%
EB Right	57	50	-12.3%
WB U-Turn	4	3	-25.0%
WB Left	278	260	-6.5%
WB Through	438	386	-11.9%
WB Right	191	181	-5.2%
NB U-Turn	6	6	0.0%
NB Left	44	35	-20.5%
NB Through	993	1110	11.8%
NB Right	149	148	-0.7%
SB U-Turn	30	29	-3.3%
SB Left	278	312	12.2%
SB Through	1354	1324	-2.2%
SB Right	194	149	-23.2%
Total	4383	4345	-0.9%

Mission Blvd/Orchard Ave/Carlos Bee Blvd

Summary Comparison 2023 vs. 2025

PM Peak Hour

2023 Data Collection: 2/15/2023

2023 Peak Hour: 16:15 - 17:15

2025 Data Collection: 1/29/2025

2025 Peak Hour: 16:30 - 17:30

Volume	2023	2025	% Difference
EB U-Turn	0	0	0.0%
EB Left Turn	84	122	45.2%
EB Through	234	293	25.2%
EB Right	56	59	5.4%
WB U-Turn	4	0	-100.0%
WB Left	155	177	14.2%
WB Through	246	273	11.0%
WB Right	203	226	11.3%
NB U-Turn	15	10	-33.3%
NB Left	79	51	-35.4%
NB Through	1432	1192	-16.8%
NB Right	361	266	-26.3%
SB U-Turn	39	43	10.3%
SB Left	236	217	-8.1%
SB Through	1191	1168	-1.9%
SB Right	155	180	16.1%
Total	4490	4277	-4.7%

Joyce St/Orchard Ave

Summary Comparison 2023 vs. 2025

AM Peak Hour

2023 Data Collection: 2/15/2023

2023 Peak Hour: 7:30 - 8:30

2025 Data Collection: 1/29/2025

2025 Peak Hour: 7:30 - 8:30

Volume	2023	2025	% Difference
EB U-Turn	1	2	100.0%
EB Left Turn	13	9	-30.8%
EB Through	373	377	1.1%
EB Right	1	2	100.0%
WB U-Turn	1	4	300.0%
WB Left	2	3	50.0%
WB Through	646	579	-10.4%
WB Right	34	37	8.8%
NB U-Turn	0	0	0.0%
NB Left	7	7	0.0%
NB Through	4	2	-50.0%
NB Right	6	6	0.0%
SB U-Turn	1	0	-100.0%
SB Left	26	28	7.7%
SB Through	1	1	0.0%
SB Right	21	22	4.8%
Total	1137	1079	-5.1%

Joyce St/Orchard Ave

Summary Comparison 2023 vs. 2025

PM Peak Hour

2023 Data Collection: 2/15/2023

2023 Peak Hour: 16:45 - 17:45

2025 Data Collection: 1/29/2025

2025 Peak Hour: 16:30 - 17:30

Volume	2023	2025	% Difference
EB U-Turn	1	1	0.0%
EB Left Turn	14	12	-14.3%
EB Through	402	472	17.4%
EB Right	4	3	-25.0%
WB U-Turn	4	5	25.0%
WB Left	9	8	-11.1%
WB Through	425	482	13.4%
WB Right	28	28	0.0%
NB U-Turn	0	0	0.0%
NB Left	6	1	-83.3%
NB Through	1	0	-100.0%
NB Right	10	12	20.0%
SB U-Turn	0	0	0.0%
SB Left	16	26	62.5%
SB Through	1	4	300.0%
SB Right	3	9	200.0%
Total	924	1063	15.0%

Vehicle Classification Report Summary

Location: Orchard Ave, Between Muir St and Thomas Ave
Count Direction: Eastbound / Westbound
Date Range: 1/31/2023 to 2/2/2023
Site Code: 03

	FHWA Vehicle Classification													Total Volume
	1	2	3	4	5	6	7	8	9	10	11	12	13	
Study Total														
Eastbound	46	13,381	2,412	2	801	19	0	0	6	1	0	0	2	16,670
Percent	0.3%	80.3%	14.5%	0.0%	4.8%	0.1%	0.0%	0.0%	0.0%	0.0%	0.0%	0.0%	0.0%	100%
Westbound	54	16,141	2,760	5	953	26	0	2	2	5	0	0	1	19,949
Percent	0.3%	80.9%	13.8%	0.0%	4.8%	0.1%	0.0%	0.0%	0.0%	0.0%	0.0%	0.0%	0.0%	100%
Total	100	29,522	5,172	7	1,754	45	0	2	8	6	0	0	3	36,619
Percent	0.3%	80.6%	14.1%	0.0%	4.8%	0.1%	0.0%	0.0%	0.0%	0.0%	0.0%	0.0%	0.0%	100%

FHWA Vehicle Classification	
Class 1 - Motorcycles	Class 8 - Four or Fewer Axle Single-Trailer Trucks
Class 2 - Passenger Cars	Class 9 - Five-Axle Single-Trailer Trucks
Class 3 - Other Two-Axle, Four-Tire Single Unit Vehicles	Class 10 - Six or More Axle Single-Trailer Trucks
Class 4 - Buses	Class 11 - Five or fewer Axle Multi-Trailer Trucks
Class 5 - Two-Axle, Six-Tire, Single-Unit Trucks	Class 12 - Six-Axle Multi-Trailer Trucks
Class 6 - Three-Axle Single-Unit Trucks	Class 13 - Seven or More Axle Multi-Trailer Trucks
Class 7 - Four or More Axle Single-Unit Trucks	

Vehicle Speed Report Summary

Location: Orchard Ave, Between Muir St and Thomas Ave
Count Direction: Eastbound / Westbound
Date Range: 1/31/2023 to 2/2/2023
Site Code: 03

	Speed Range (mph)																	Total Volume
	0 - 10	10 - 15	15 - 20	20 - 25	25 - 30	30 - 35	35 - 40	40 - 45	45 - 50	50 - 55	55 - 60	60 - 65	65 - 70	70 - 75	75 - 80	80 - 85	85 +	
Study Total																		
Eastbound	23	136	1,390	6,522	6,656	1,711	207	21	3	0	0	0	1	0	0	0	0	16,670
Percent	0.1%	0.8%	8.3%	39.1%	39.9%	10.3%	1.2%	0.1%	0.0%	0.0%	0.0%	0.0%	0.0%	0.0%	0.0%	0.0%	0.0%	100%
Westbound	49	426	2,487	8,631	6,459	1,610	243	29	10	4	1	0	0	0	0	0	0	19,949
Percent	0.2%	2.1%	12.5%	43.3%	32.4%	8.1%	1.2%	0.1%	0.1%	0.0%	0.0%	0.0%	0.0%	0.0%	0.0%	0.0%	0.0%	100%
Total	72	562	3,877	15,153	13,115	3,321	450	50	13	4	1	0	1	0	0	0	0	36,619
Percent	0.2%	1.5%	10.6%	41.4%	35.8%	9.1%	1.2%	0.1%	0.0%	0.0%	0.0%	0.0%	0.0%	0.0%	0.0%	0.0%	0.0%	100%

Total Study Percentile Speed Summary			Total Study Speed Statistics		
Eastbound			Eastbound		
50th Percentile (Median)	25.2	mph	Mean (Average) Speed	25.2	mph
85th Percentile	29.3	mph	10 mph Pace	20.5 - 30.5	mph
95th Percentile	32.1	mph	Percent in Pace	78.9	%
Westbound			Westbound		
50th Percentile (Median)	24.2	mph	Mean (Average) Speed	24.3	mph
85th Percentile	28.6	mph	10 mph Pace	19.2 - 29.2	mph
95th Percentile	31.8	mph	Percent in Pace	76.2	%

Location: Orchard Ave, Between Muir St and Thomas Ave
 Date Range: 1/31/2023 - 2/6/2023
 Site Code: 03

Time	Tuesday			Wednesday			Thursday			Friday			Saturday			Sunday			Monday			Mid-Week Average		
	1/31/2023			2/1/2023			2/2/2023			2/3/2023			2/4/2023			2/5/2023			2/6/2023					
	EB	WB	Total	EB	WB	Total	EB	WB	Total	EB	WB	Total	EB	WB	Total	EB	WB	Total	EB	WB	Total	EB	WB	Total
12:00 AM	52	17	69	48	17	65	58	34	92	-	-	-	-	-	-	-	-	-	-	-	-	53	23	75
1:00 AM	23	26	49	36	16	52	23	19	42	-	-	-	-	-	-	-	-	-	-	-	-	27	20	48
2:00 AM	12	18	30	12	17	29	16	26	42	-	-	-	-	-	-	-	-	-	-	-	-	13	20	34
3:00 AM	7	41	48	10	35	45	12	38	50	-	-	-	-	-	-	-	-	-	-	-	-	10	38	48
4:00 AM	24	93	117	18	97	115	24	99	123	-	-	-	-	-	-	-	-	-	-	-	-	22	96	118
5:00 AM	46	223	269	48	228	276	47	230	277	-	-	-	-	-	-	-	-	-	-	-	-	47	227	274
6:00 AM	116	346	462	123	356	479	90	317	407	-	-	-	-	-	-	-	-	-	-	-	-	110	340	449
7:00 AM	277	571	848	297	567	864	255	599	854	-	-	-	-	-	-	-	-	-	-	-	-	276	579	855
8:00 AM	416	577	993	384	528	912	426	542	968	-	-	-	-	-	-	-	-	-	-	-	-	409	549	958
9:00 AM	262	347	609	259	376	635	287	377	664	-	-	-	-	-	-	-	-	-	-	-	-	269	367	636
10:00 AM	259	355	614	241	332	573	247	365	612	-	-	-	-	-	-	-	-	-	-	-	-	249	351	600
11:00 AM	274	362	636	246	399	645	241	332	573	-	-	-	-	-	-	-	-	-	-	-	-	254	364	618
12:00 PM	302	414	716	329	415	744	283	369	652	-	-	-	-	-	-	-	-	-	-	-	-	305	399	704
1:00 PM	358	415	773	369	425	794	316	354	670	-	-	-	-	-	-	-	-	-	-	-	-	348	398	746
2:00 PM	341	420	761	359	413	772	366	443	809	-	-	-	-	-	-	-	-	-	-	-	-	355	425	781
3:00 PM	376	417	793	418	450	868	393	511	904	-	-	-	-	-	-	-	-	-	-	-	-	396	459	855
4:00 PM	427	433	860	453	454	907	463	432	895	-	-	-	-	-	-	-	-	-	-	-	-	448	440	887
5:00 PM	454	478	932	433	477	910	416	436	852	-	-	-	-	-	-	-	-	-	-	-	-	434	464	898
6:00 PM	404	338	742	425	359	784	423	364	787	-	-	-	-	-	-	-	-	-	-	-	-	417	354	771
7:00 PM	366	258	624	361	263	624	343	261	604	-	-	-	-	-	-	-	-	-	-	-	-	357	261	617
8:00 PM	292	171	463	310	189	499	281	180	461	-	-	-	-	-	-	-	-	-	-	-	-	294	180	474
9:00 PM	246	159	405	201	149	350	228	159	387	-	-	-	-	-	-	-	-	-	-	-	-	225	156	381
10:00 PM	148	102	250	145	81	226	153	95	248	-	-	-	-	-	-	-	-	-	-	-	-	149	93	241
11:00 PM	88	52	140	82	45	127	102	46	148	-	-	-	-	-	-	-	-	-	-	-	-	91	48	138
Total	5,570	6,633	12,203	5,607	6,688	12,295	5,493	6,628	12,121	-	-	-	-	-	-	-	-	-	-	-	-	5,557	6,650	12,206
Percent	46%	54%	-	46%	54%	-	45%	55%	-	-	-	-	-	-	-	-	-	-	-	-	-	46%	54%	-
AM Peak	08:00	08:00	08:00	08:00	07:00	08:00	08:00	07:00	08:00	-	-	-	-	-	-	-	-	-	-	-	-	08:00	07:00	08:00
Vol.	416	577	993	384	567	912	426	599	968	-	-	-	-	-	-	-	-	-	-	-	-	409	579	958
PM Peak	17:00	17:00	17:00	16:00	17:00	17:00	16:00	15:00	15:00	-	-	-	-	-	-	-	-	-	-	-	-	16:00	17:00	17:00
Vol.	454	478	932	453	477	910	463	511	904	-	-	-	-	-	-	-	-	-	-	-	-	448	464	898

1. Mid-week average includes data between Tuesday and Thursday.

Vehicle Classification Report Summary

Location: Orchard Ave, Between Oneil Ave & Joyce St
Count Direction: Eastbound / Westbound
Date Range: 1/31/2023 to 2/2/2023
Site Code: 04

	FHWA Vehicle Classification													Total Volume
	1	2	3	4	5	6	7	8	9	10	11	12	13	
Study Total														
Eastbound	41	13,690	2,403	2	798	73	0	4	8	10	0	1	2	17,032
Percent	0.2%	80.4%	14.1%	0.0%	4.7%	0.4%	0.0%	0.0%	0.0%	0.1%	0.0%	0.0%	0.0%	100%
Westbound	56	17,032	2,216	4	546	23	0	12	7	15	2	0	11	19,924
Percent	0.3%	85.5%	11.1%	0.0%	2.7%	0.1%	0.0%	0.1%	0.0%	0.1%	0.0%	0.0%	0.1%	100%
Total	97	30,722	4,619	6	1,344	96	0	16	15	25	2	1	13	36,956
Percent	0.3%	83.1%	12.5%	0.0%	3.6%	0.3%	0.0%	0.0%	0.0%	0.1%	0.0%	0.0%	0.0%	100%

FHWA Vehicle Classification	
Class 1 - Motorcycles	Class 8 - Four or Fewer Axle Single-Trailer Trucks
Class 2 - Passenger Cars	Class 9 - Five-Axle Single-Trailer Trucks
Class 3 - Other Two-Axle, Four-Tire Single Unit Vehicles	Class 10 - Six or More Axle Single-Trailer Trucks
Class 4 - Buses	Class 11 - Five or fewer Axle Multi-Trailer Trucks
Class 5 - Two-Axle, Six-Tire, Single-Unit Trucks	Class 12 - Six-Axle Multi-Trailer Trucks
Class 6 - Three-Axle Single-Unit Trucks	Class 13 - Seven or More Axle Multi-Trailer Trucks
Class 7 - Four or More Axle Single-Unit Trucks	

Vehicle Speed Report Summary

Location: Orchard Ave, Between Oneil Ave & Joyce St
Count Direction: Eastbound / Westbound
Date Range: 1/31/2023 to 2/2/2023
Site Code: 04

	Speed Range (mph)																	Total Volume
	0 - 10	10 - 15	15 - 20	20 - 25	25 - 30	30 - 35	35 - 40	40 - 45	45 - 50	50 - 55	55 - 60	60 - 65	65 - 70	70 - 75	75 - 80	80 - 85	85 +	
Study Total																		
Eastbound	5	17	44	295	1,844	5,419	5,976	2,603	621	161	33	9	4	1	0	0	0	17,032
Percent	0.0%	0.1%	0.3%	1.7%	10.8%	31.8%	35.1%	15.3%	3.6%	0.9%	0.2%	0.1%	0.0%	0.0%	0.0%	0.0%	0.0%	100%
Westbound	2	11	30	285	1,508	4,587	8,166	4,001	1,053	212	50	14	5	0	0	0	0	19,924
Percent	0.0%	0.1%	0.2%	1.4%	7.6%	23.0%	41.0%	20.1%	5.3%	1.1%	0.3%	0.1%	0.0%	0.0%	0.0%	0.0%	0.0%	100%
Total	7	28	74	580	3,352	10,006	14,142	6,604	1,674	373	83	23	9	1	0	0	0	36,956
Percent	0.0%	0.1%	0.2%	1.6%	9.1%	27.1%	38.3%	17.9%	4.5%	1.0%	0.2%	0.1%	0.0%	0.0%	0.0%	0.0%	0.0%	100%

Total Study Percentile Speed Summary			Total Study Speed Statistics		
Eastbound			Eastbound		
50th Percentile (Median)	35.7	mph	Mean (Average) Speed	35.8	mph
85th Percentile	41.2	mph	10 mph Pace	30.5 - 40.5	mph
95th Percentile	45.0	mph	Percent in Pace	67.2	%
Westbound			Westbound		
50th Percentile (Median)	37.1	mph	Mean (Average) Speed	37.1	mph
85th Percentile	42.2	mph	10 mph Pace	32.4 - 42.4	mph
95th Percentile	46.0	mph	Percent in Pace	69.0	%

Location: Orchard Ave, Between Oneil Ave & Joyce St
 Date Range: 1/31/2023 - 2/6/2023
 Site Code: 04

Time	Tuesday			Wednesday			Thursday			Friday			Saturday			Sunday			Monday			Mid-Week Average		
	1/31/2023			2/1/2023			2/2/2023			2/3/2023			2/4/2023			2/5/2023			2/6/2023					
	EB	WB	Total	EB	WB	Total	EB	WB	Total	EB	WB	Total	EB	WB	Total	EB	WB	Total	EB	WB	Total	EB	WB	Total
12:00 AM	54	15	69	50	19	69	60	38	98	-	-	-	-	-	-	-	-	-	-	-	-	55	24	79
1:00 AM	22	24	46	36	13	49	24	19	43	-	-	-	-	-	-	-	-	-	-	-	-	27	19	46
2:00 AM	11	17	28	12	14	26	18	27	45	-	-	-	-	-	-	-	-	-	-	-	-	14	19	33
3:00 AM	8	37	45	12	29	41	13	31	44	-	-	-	-	-	-	-	-	-	-	-	-	11	32	43
4:00 AM	33	85	118	25	89	114	26	91	117	-	-	-	-	-	-	-	-	-	-	-	-	28	88	116
5:00 AM	55	210	265	49	208	257	50	203	253	-	-	-	-	-	-	-	-	-	-	-	-	51	207	258
6:00 AM	123	327	450	141	326	467	113	300	413	-	-	-	-	-	-	-	-	-	-	-	-	126	318	443
7:00 AM	306	520	826	313	529	842	290	581	871	-	-	-	-	-	-	-	-	-	-	-	-	303	543	846
8:00 AM	437	573	1,010	405	552	957	424	542	966	-	-	-	-	-	-	-	-	-	-	-	-	422	556	978
9:00 AM	268	348	616	279	368	647	313	377	690	-	-	-	-	-	-	-	-	-	-	-	-	287	364	651
10:00 AM	276	358	634	248	338	586	242	344	586	-	-	-	-	-	-	-	-	-	-	-	-	255	347	602
11:00 AM	273	363	636	255	379	634	252	349	601	-	-	-	-	-	-	-	-	-	-	-	-	260	364	624
12:00 PM	339	403	742	322	419	741	309	356	665	-	-	-	-	-	-	-	-	-	-	-	-	323	393	716
1:00 PM	375	420	795	380	447	827	331	356	687	-	-	-	-	-	-	-	-	-	-	-	-	362	408	770
2:00 PM	345	419	764	383	422	805	388	448	836	-	-	-	-	-	-	-	-	-	-	-	-	372	430	802
3:00 PM	388	418	806	434	468	902	417	529	946	-	-	-	-	-	-	-	-	-	-	-	-	413	472	885
4:00 PM	416	428	844	410	465	875	417	467	884	-	-	-	-	-	-	-	-	-	-	-	-	414	453	868
5:00 PM	450	513	963	450	499	949	424	446	870	-	-	-	-	-	-	-	-	-	-	-	-	441	486	927
6:00 PM	430	359	789	417	358	775	399	367	766	-	-	-	-	-	-	-	-	-	-	-	-	415	361	777
7:00 PM	381	261	642	362	261	623	342	263	605	-	-	-	-	-	-	-	-	-	-	-	-	362	262	623
8:00 PM	287	179	466	297	191	488	269	179	448	-	-	-	-	-	-	-	-	-	-	-	-	284	183	467
9:00 PM	235	157	392	203	150	353	227	174	401	-	-	-	-	-	-	-	-	-	-	-	-	222	160	382
10:00 PM	142	107	249	140	95	235	139	95	234	-	-	-	-	-	-	-	-	-	-	-	-	140	99	239
11:00 PM	87	54	141	83	55	138	98	53	151	-	-	-	-	-	-	-	-	-	-	-	-	89	54	143
Total	5,741	6,595	12,336	5,706	6,694	12,400	5,585	6,635	12,220	-	-	-	-	-	-	-	-	-	-	-	-	5,677	6,641	12,319
Percent	47%	53%	-	46%	54%	-	46%	54%	-	-	-	-	-	-	-	-	-	-	-	-	-	46%	54%	-
AM Peak	08:00	08:00	08:00	08:00	08:00	08:00	08:00	07:00	08:00	-	-	-	-	-	-	-	-	-	-	-	-	08:00	08:00	08:00
Vol.	437	573	1,010	405	552	957	424	581	966	-	-	-	-	-	-	-	-	-	-	-	-	422	556	978
PM Peak	17:00	17:00	17:00	17:00	17:00	17:00	17:00	15:00	15:00	-	-	-	-	-	-	-	-	-	-	-	-	17:00	17:00	17:00
Vol.	450	513	963	450	499	949	424	529	946	-	-	-	-	-	-	-	-	-	-	-	-	441	486	927

1. Mid-week average includes data between Tuesday and Thursday.

Vehicle Classification Report Summary

Location: Orchard Ave, Between Muir St & Thomas Ave
Count Direction: Eastbound / Westbound
Date Range: 1/28/2025 to 1/30/2025
Site Code: 02

Direction	FHWA Vehicle Classification													Total Volume
	1	2	3	4	5	6	7	8	9	10	11	12	13	
Eastbound	60	13,814	2,268	49	262	19	0	0	5	0	0	0	0	16,477
	0.4%	83.8%	13.8%	0.3%	1.6%	0.1%	0.0%	0.0%	0.0%	0.0%	0.0%	0.0%	0.0%	
Westbound	62	16,648	2,284	59	311	18	0	2	3	0	0	0	1	19,388
	0.3%	85.9%	11.8%	0.3%	1.6%	0.1%	0.0%	0.0%	0.0%	0.0%	0.0%	0.0%	0.0%	
Total	122	30,462	4,552	108	573	37	0	2	8	0	0	0	1	35,865
	0.3%	84.9%	12.7%	0.3%	1.6%	0.1%	0.0%	0.0%	0.0%	0.0%	0.0%	0.0%	0.0%	

FHWA Vehicle Classification	
Class 1 - Motorcycles	Class 8 - Four or Fewer Axle Single-Trailer Trucks
Class 2 - Passenger Cars	Class 9 - Five-Axle Single-Trailer Trucks
Class 3 - Other Two-Axle, Four-Tire Single Unit Vehicles	Class 10 - Six or More Axle Single-Trailer Trucks
Class 4 - Buses	Class 11 - Five or fewer Axle Multi-Trailer Trucks
Class 5 - Two-Axle, Six-Tire, Single-Unit Trucks	Class 12 - Six-Axle Multi-Trailer Trucks
Class 6 - Three-Axle Single-Unit Trucks	Class 13 - Seven or More Axle Multi-Trailer Trucks
Class 7 - Four or More Axle Single-Unit Trucks	

Vehicle Speed Report Summary



Location: Orchard Ave, Between Muir St & Thomas Ave
Direction: Eastbound / Westbound
Date Range: 1/28/2025 to 1/30/2025
Site Code: 02

Direction	Speed Range (mph)																	Total Volume
	0 - 10	10 - 15	15 - 20	20 - 25	25 - 30	30 - 35	35 - 40	40 - 45	45 - 50	50 - 55	55 - 60	60 - 65	65 - 70	70 - 75	75 - 80	80 - 85	85 +	
Eastbound	41	238	2,118	7,307	5,471	1,150	128	17	1	3	1	0	1	0	0	0	1	16,477
	0.2%	1.4%	12.9%	44.3%	33.2%	7.0%	0.8%	0.1%	0.0%	0.0%	0.0%	0.0%	0.0%	0.0%	0.0%	0.0%	0.0%	
Westbound	87	507	3,262	9,609	5,124	720	62	14	2	0	0	0	0	0	0	0	1	19,388
	0.4%	2.6%	16.8%	49.6%	26.4%	3.7%	0.3%	0.1%	0.0%	0.0%	0.0%	0.0%	0.0%	0.0%	0.0%	0.0%	0.0%	
Total	128	745	5,380	16,916	10,595	1,870	190	31	3	3	1	0	1	0	0	0	2	35,865
	0.4%	2.1%	15.0%	47.2%	29.5%	5.2%	0.5%	0.1%	0.0%	0.0%	0.0%	0.0%	0.0%	0.0%	0.0%	0.0%	0.0%	

Total Study Percentile Speed Summary			Total Study Speed Statistics		
Eastbound			Eastbound		
50th Percentile (Median)	24.2	mph	Mean (Average) Speed	24.2	mph
85th Percentile	28.3	mph	10 mph Pace	19.1 - 29.1	mph
95th Percentile	31.1	mph	Percent in Pace	78.7	%
Westbound			Westbound		
50th Percentile (Median)	23.2	mph	Mean (Average) Speed	23.1	mph
85th Percentile	27.1	mph	10 mph Pace	18.3 - 28.3	mph
95th Percentile	29.5	mph	Percent in Pace	80.2	%

Location: Orchard Ave, Between Muir St & Thomas Ave
 Date Range: 1/28/2025 - 2/3/2025
 Site Code: 02

Time	Tuesday 1/28/2025			Wednesday 1/29/2025			Thursday 1/30/2025			Friday 1/31/2025			Saturday 2/1/2025			Sunday 2/2/2025			Monday 2/3/2025			Mid-Week Average		
	EB	WB	Total	EB	WB	Total	EB	WB	Total	EB	WB	Total	EB	WB	Total	EB	WB	Total	EB	WB	Total	EB	WB	Total
12:00 AM	50	22	72	55	23	78	45	26	71	-	-	-	-	-	-	-	-	-	50	24	74			
1:00 AM	33	29	62	26	19	45	26	20	46	-	-	-	-	-	-	-	-	-	28	23	51			
2:00 AM	13	23	36	23	17	40	19	20	39	-	-	-	-	-	-	-	-	-	18	20	38			
3:00 AM	22	42	64	18	44	62	18	41	59	-	-	-	-	-	-	-	-	-	19	42	62			
4:00 AM	17	97	114	27	100	127	22	109	131	-	-	-	-	-	-	-	-	-	22	102	124			
5:00 AM	46	229	275	41	220	261	64	226	290	-	-	-	-	-	-	-	-	-	50	225	275			
6:00 AM	127	375	502	113	331	444	131	364	495	-	-	-	-	-	-	-	-	-	124	357	480			
7:00 AM	255	512	767	259	584	843	273	543	816	-	-	-	-	-	-	-	-	-	262	546	809			
8:00 AM	381	507	888	411	517	928	376	514	890	-	-	-	-	-	-	-	-	-	389	513	902			
9:00 AM	284	392	676	221	379	600	270	430	700	-	-	-	-	-	-	-	-	-	258	400	659			
10:00 AM	236	366	602	230	359	589	242	358	600	-	-	-	-	-	-	-	-	-	236	361	597			
11:00 AM	249	324	573	233	371	604	259	345	604	-	-	-	-	-	-	-	-	-	247	347	594			
12:00 PM	232	314	546	320	358	678	317	413	730	-	-	-	-	-	-	-	-	-	290	362	651			
1:00 PM	320	362	682	326	441	767	342	371	713	-	-	-	-	-	-	-	-	-	329	391	721			
2:00 PM	353	358	711	359	341	700	343	355	698	-	-	-	-	-	-	-	-	-	352	351	703			
3:00 PM	426	427	853	409	432	841	393	448	841	-	-	-	-	-	-	-	-	-	409	436	845			
4:00 PM	467	449	916	471	450	921	476	446	922	-	-	-	-	-	-	-	-	-	471	448	920			
5:00 PM	502	439	941	454	450	904	456	439	895	-	-	-	-	-	-	-	-	-	471	443	913			
6:00 PM	377	355	732	414	369	783	401	375	776	-	-	-	-	-	-	-	-	-	397	366	764			
7:00 PM	313	243	556	354	218	572	323	233	556	-	-	-	-	-	-	-	-	-	330	231	561			
8:00 PM	282	209	491	276	184	460	280	188	468	-	-	-	-	-	-	-	-	-	279	194	473			
9:00 PM	208	134	342	190	147	337	238	150	388	-	-	-	-	-	-	-	-	-	212	144	356			
10:00 PM	141	84	225	153	79	232	153	99	252	-	-	-	-	-	-	-	-	-	149	87	236			
11:00 PM	89	45	134	96	52	148	108	53	161	-	-	-	-	-	-	-	-	-	98	50	148			
Total	5,423	6,337	11,760	5,479	6,485	11,964	5,575	6,566	12,141	-	-	-	-	-	-	-	-	-	5,492	6,463	11,955			
Percent	46%	54%		46%	54%		46%	54%		-	-	-	-	-	-	-	-	-	46%	54%				
AM Peak	08:00	07:00	08:00	08:00	07:00	08:00	08:00	07:00	08:00	-	-	-	-	-	-	-	-	-	08:00	07:00	08:00			
Vol.	381	512	888	411	584	928	376	543	890	-	-	-	-	-	-	-	-	-	389	546	902			
PM Peak	17:00	16:00	17:00	16:00	16:00	16:00	16:00	15:00	16:00	-	-	-	-	-	-	-	-	-	16:00	16:00	16:00			
Vol.	502	449	941	471	450	921	476	448	922	-	-	-	-	-	-	-	-	-	471	448	920			

1. Mid-week average includes data between Tuesday and Thursday.

Vehicle Classification Report Summary

Location: Orchard Ave, Between Joyce St & Oneil Ave
Count Direction: Eastbound / Westbound
Date Range: 1/28/2025 to 1/30/2025
Site Code: 01

Direction	FHWA Vehicle Classification													Total Volume
	1	2	3	4	5	6	7	8	9	10	11	12	13	
Eastbound	45	14,225	2,265	51	302	21	0	1	4	0	0	0	0	16,914
	0.3%	84.1%	13.4%	0.3%	1.8%	0.1%	0.0%	0.0%	0.0%	0.0%	0.0%	0.0%	0.0%	
Westbound	43	17,098	2,475	52	331	18	0	3	5	0	0	0	0	20,025
	0.2%	85.4%	12.4%	0.3%	1.7%	0.1%	0.0%	0.0%	0.0%	0.0%	0.0%	0.0%	0.0%	
Total	88	31,323	4,740	103	633	39	0	4	9	0	0	0	0	36,939
	0.2%	84.8%	12.8%	0.3%	1.7%	0.1%	0.0%	0.0%	0.0%	0.0%	0.0%	0.0%	0.0%	

FHWA Vehicle Classification	
Class 1 - Motorcycles	Class 8 - Four or Fewer Axle Single-Trailer Trucks
Class 2 - Passenger Cars	Class 9 - Five-Axle Single-Trailer Trucks
Class 3 - Other Two-Axle, Four-Tire Single Unit Vehicles	Class 10 - Six or More Axle Single-Trailer Trucks
Class 4 - Buses	Class 11 - Five or fewer Axle Multi-Trailer Trucks
Class 5 - Two-Axle, Six-Tire, Single-Unit Trucks	Class 12 - Six-Axle Multi-Trailer Trucks
Class 6 - Three-Axle Single-Unit Trucks	Class 13 - Seven or More Axle Multi-Trailer Trucks
Class 7 - Four or More Axle Single-Unit Trucks	

Vehicle Speed Report Summary



Location: Orchard Ave, Between Joyce St & Oneil Ave
Direction: Eastbound / Westbound
Date Range: 1/28/2025 to 1/30/2025
Site Code: 01

Direction	Speed Range (mph)																	Total Volume
	0 - 10	10 - 15	15 - 20	20 - 25	25 - 30	30 - 35	35 - 40	40 - 45	45 - 50	50 - 55	55 - 60	60 - 65	65 - 70	70 - 75	75 - 80	80 - 85	85 +	
Eastbound	10	42	180	943	3,578	6,348	4,138	1,352	246	58	16	3	0	0	0	0	0	16,914
	0.1%	0.2%	1.1%	5.6%	21.2%	37.5%	24.5%	8.0%	1.5%	0.3%	0.1%	0.0%	0.0%	0.0%	0.0%	0.0%	0.0%	
Westbound	1	1	18	257	2,090	7,211	7,482	2,410	452	83	16	4	0	0	0	0	0	20,025
	0.0%	0.0%	0.1%	1.3%	10.4%	36.0%	37.4%	12.0%	2.3%	0.4%	0.1%	0.0%	0.0%	0.0%	0.0%	0.0%	0.0%	
Total	11	43	198	1,200	5,668	13,559	11,620	3,762	698	141	32	7	0	0	0	0	0	36,939
	0.0%	0.1%	0.5%	3.2%	15.3%	36.7%	31.5%	10.2%	1.9%	0.4%	0.1%	0.0%	0.0%	0.0%	0.0%	0.0%	0.0%	

Total Study Percentile Speed Summary			Total Study Speed Statistics		
Eastbound			Eastbound		
50th Percentile (Median)	32.9	mph	Mean (Average) Speed	33.0	mph
85th Percentile	38.5	mph	10 mph Pace	27.8 - 37.8	mph
95th Percentile	42.2	mph	Percent in Pace	66.0	%
Westbound			Westbound		
50th Percentile (Median)	35.2	mph	Mean (Average) Speed	35.3	mph
85th Percentile	39.9	mph	10 mph Pace	30.4 - 40.4	mph
95th Percentile	43.2	mph	Percent in Pace	73.3	%

Location: Orchard Ave, Between Joyce St & Oneil Ave
 Date Range: 1/28/2025 - 2/3/2025
 Site Code: 01

Time	Tuesday 1/28/2025			Wednesday 1/29/2025			Thursday 1/30/2025			Friday 1/31/2025			Saturday 2/1/2025			Sunday 2/2/2025			Monday 2/3/2025			Mid-Week Average		
	EB	WB	Total	EB	WB	Total	EB	WB	Total	EB	WB	Total	EB	WB	Total	EB	WB	Total	EB	WB	Total	EB	WB	Total
12:00 AM	54	24	78	52	26	78	43	25	68	-	-	-	-	-	-	-	-	-	50	25	75			
1:00 AM	28	31	59	26	19	45	23	20	43	-	-	-	-	-	-	-	-	-	26	23	49			
2:00 AM	12	21	33	24	17	41	15	21	36	-	-	-	-	-	-	-	-	-	17	20	37			
3:00 AM	21	37	58	17	35	52	17	34	51	-	-	-	-	-	-	-	-	-	18	35	54			
4:00 AM	22	89	111	36	91	127	28	101	129	-	-	-	-	-	-	-	-	-	29	94	122			
5:00 AM	52	215	267	50	202	252	64	209	273	-	-	-	-	-	-	-	-	-	55	209	264			
6:00 AM	138	344	482	124	302	426	144	334	478	-	-	-	-	-	-	-	-	-	135	327	462			
7:00 AM	296	525	821	296	590	886	302	523	825	-	-	-	-	-	-	-	-	-	298	546	844			
8:00 AM	387	523	910	427	529	956	401	543	944	-	-	-	-	-	-	-	-	-	405	532	937			
9:00 AM	318	427	745	236	367	603	295	419	714	-	-	-	-	-	-	-	-	-	283	404	687			
10:00 AM	257	378	635	236	370	606	242	366	608	-	-	-	-	-	-	-	-	-	245	371	616			
11:00 AM	243	373	616	230	367	597	259	349	608	-	-	-	-	-	-	-	-	-	244	363	607			
12:00 PM	310	379	689	334	376	710	331	441	772	-	-	-	-	-	-	-	-	-	325	399	724			
1:00 PM	332	383	715	335	430	765	340	392	732	-	-	-	-	-	-	-	-	-	336	402	737			
2:00 PM	372	369	741	373	357	730	350	372	722	-	-	-	-	-	-	-	-	-	365	366	731			
3:00 PM	439	447	886	411	448	859	402	470	872	-	-	-	-	-	-	-	-	-	417	455	872			
4:00 PM	451	487	938	492	487	979	463	517	980	-	-	-	-	-	-	-	-	-	469	497	966			
5:00 PM	503	473	976	465	478	943	461	497	958	-	-	-	-	-	-	-	-	-	476	483	959			
6:00 PM	379	373	752	411	383	794	418	403	821	-	-	-	-	-	-	-	-	-	403	386	789			
7:00 PM	302	258	560	352	224	576	318	259	577	-	-	-	-	-	-	-	-	-	324	247	571			
8:00 PM	272	206	478	267	182	449	271	192	463	-	-	-	-	-	-	-	-	-	270	193	463			
9:00 PM	208	140	348	181	157	338	241	147	388	-	-	-	-	-	-	-	-	-	210	148	358			
10:00 PM	135	91	226	148	87	235	145	108	253	-	-	-	-	-	-	-	-	-	143	95	238			
11:00 PM	91	60	151	90	55	145	106	51	157	-	-	-	-	-	-	-	-	-	96	55	151			
Total	5,622	6,653	12,275	5,613	6,579	12,192	5,679	6,793	12,472	-	-	-	-	-	-	-	-	-	5,638	6,675	12,313			
Percent	46%	54%		46%	54%		46%	54%		-	-	-	-	-	-	-	-	-	46%	54%				
AM Peak	08:00	07:00	08:00	08:00	07:00	08:00	08:00	08:00	08:00	-	-	-	-	-	-	-	-	-	08:00	07:00	08:00			
Vol.	387	525	910	427	590	956	401	543	944	-	-	-	-	-	-	-	-	-	405	546	937			
PM Peak	17:00	16:00	17:00	16:00	16:00	16:00	16:00	16:00	16:00	-	-	-	-	-	-	-	-	-	17:00	16:00	16:00			
Vol.	503	487	976	492	487	979	463	517	980	-	-	-	-	-	-	-	-	-	476	497	966			

1. Mid-week average includes data between Tuesday and Thursday.

Joyce St Orchard Ave



Peak Hour

Date: 2/15/2023
 Count Period: 7:00 AM to 11:00 AM
 Peak Hour: 7:30 AM to 8:30 AM

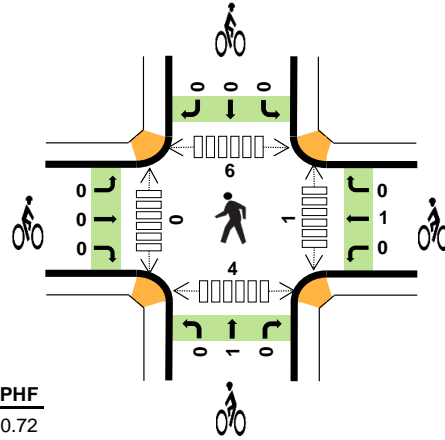
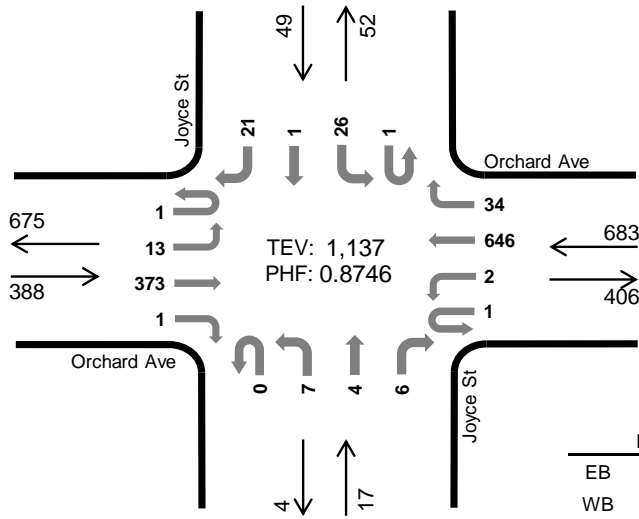

	HV%	PHF
EB	3%	0.72
WB	1%	0.80
NB	0%	0.71
SB	0%	0.58
TOTAL	2%	0.87

Peak Hour Count Summaries

Peak Hour Interval Start	Orchard Ave				Orchard Ave				Joyce St				Joyce St				15-min Total	Rolling Hour Total	
	Eastbound		Westbound		Northbound		Southbound		Northbound		Southbound								
	UT	LT	TH	RT	UT	LT	TH	RT	UT	LT	TH	RT	UT	LT	TH	RT			
7:30 AM	0	2	72	0	0	0	152	12	0	2	2	1	0	7	0	3	253	0	
7:45 AM	1	2	91	0	0	2	203	9	0	2	0	2	0	4	1	8	325	0	
8:00 AM	0	6	128	0	0	0	145	8	0	3	1	2	1	11	0	9	314	0	
8:15 AM	0	3	82	1	1	0	146	5	0	0	1	1	0	4	0	1	245	1,137	
Pk Hr	All	1	13	373	1	1	2	646	34	0	7	4	6	1	26	1	21	1,137	
	HV	1	2	10	0	0	0	9	0	0	0	0	0	0	0	0	0	22	
	HV%	100%	15%	3%	0%	0%	0%	1%	0%	-	0%	0%	0%	0%	0%	0%	0%	2%	

Note: For complete count summary (all intervals), see following pages.

** Heavy Vehicle Classifications include FHWA Classes 4-13.

** Count Summaries include heavy vehicles, but exclude bicycles in overall count.

Interval Start	Heavy Vehicle Totals					Bicycles				Pedestrians (Crossing Leg)					
	EB	WB	NB	SB	Total	EB	WB	NB	SB	Total	E	W	N	S	Total
7:30 AM	4	2	0	0	6	0	1	0	0	1	1	0	2	2	5
7:45 AM	2	3	0	0	5	0	0	0	0	0	0	0	1	1	2
8:00 AM	5	2	0	0	7	0	0	0	0	0	0	0	0	0	0
8:15 AM	2	2	0	0	4	0	0	1	0	1	0	0	3	1	4
Peak Hour	13	9	0	0	22	0	1	1	0	2	1	0	6	4	11

Count Summaries - All Vehicles

Interval Start	Orchard Ave				Orchard Ave				Joyce St				Joyce St				15-min Total	Rolling Hour Total	
	Eastbound				Westbound				Northbound				Southbound						
	UT	LT	TH	RT	UT	LT	TH	RT	UT	LT	TH	RT	UT	LT	TH	RT			
7:00 AM	0	1	48	0	1	0	92	4	0	2	0	1	0	3	0	0	152	0	
7:15 AM	1	0	60	0	1	2	116	11	0	0	0	2	0	5	0	4	202	0	
7:30 AM	0	2	72	0	0	0	152	12	0	2	2	1	0	7	0	3	253	0	
7:45 AM	1	2	91	0	0	2	203	9	0	2	0	2	0	4	1	8	325	932	
8:00 AM	0	6	128	0	0	0	145	8	0	3	1	2	1	11	0	9	314	1,094	
8:15 AM	0	3	82	1	1	0	146	5	0	0	1	1	0	4	0	1	245	1,137	
8:30 AM	0	4	91	2	0	1	136	9	0	2	0	0	0	7	0	0	252	1,136	
8:45 AM	0	1	74	1	1	0	125	5	0	0	0	2	0	2	0	1	212	1,023	
9:00 AM	0	0	59	1	0	0	71	6	0	2	0	0	0	1	0	1	141	850	
9:15 AM	1	0	74	0	0	0	75	2	0	0	0	2	0	6	0	1	161	766	
9:30 AM	0	1	59	1	1	0	83	1	0	0	0	0	0	5	0	3	154	668	
9:45 AM	0	1	59	1	0	0	86	4	0	0	0	0	0	0	0	1	152	608	
10:00 AM	0	0	59	0	1	0	79	3	0	0	0	0	0	0	0	1	143	610	
10:15 AM	0	2	57	0	2	2	83	0	0	1	0	1	0	1	0	0	149	598	
10:30 AM	0	0	48	1	0	0	94	5	0	1	0	0	0	2	0	0	151	595	
10:45 AM	0	2	61	0	2	1	84	3	0	1	1	0	0	4	0	2	161	604	
Count Total	3	25	1,122	8	10	8	1,770	87	0	16	5	14	1	62	1	35	3,167		
Pk Hr	All	1	13	373	1	1	2	646	34	0	7	4	6	1	26	1	21	1,137	
	HV	1	2	10	0	0	0	9	0	0	0	0	0	0	0	0	22		
	HV%	100%	15%	3%	0%	0%	0%	1%	0%	-	0%	0%	0%	0%	0%	0%	2%		

Interval Start	Heavy Vehicle Totals					Bicycles					Pedestrians (Crossing Leg)				
	EB	WB	NB	SB	Total	EB	WB	NB	SB	Total	E	W	N	S	Total
7:00 AM	2	2	0	0	4	0	0	0	0	0	0	0	0	1	1
7:15 AM	2	3	1	0	6	0	0	0	0	0	0	0	0	0	0
7:30 AM	4	2	0	0	6	0	1	0	0	1	1	0	2	2	5
7:45 AM	2	3	0	0	5	0	0	0	0	0	0	0	1	1	2
8:00 AM	5	2	0	0	7	0	0	0	0	0	0	0	0	0	0
8:15 AM	2	2	0	0	4	0	0	1	0	1	0	0	3	1	4
8:30 AM	2	3	0	1	6	0	0	0	0	0	1	1	2	0	4
8:45 AM	2	2	0	1	5	0	0	0	0	0	0	1	2	2	5
9:00 AM	2	0	0	0	2	1	0	0	0	1	0	0	0	1	1
9:15 AM	3	0	0	1	4	0	0	0	0	0	0	0	2	0	2
9:30 AM	0	0	0	0	0	0	0	0	0	0	0	2	2	1	5
9:45 AM	0	3	0	0	3	0	0	0	0	0	0	0	0	2	2
10:00 AM	2	1	0	0	3	0	0	0	0	0	0	0	2	0	2
10:15 AM	4	1	0	0	5	0	0	0	0	0	0	0	3	0	3
10:30 AM	0	2	0	1	3	0	0	0	0	0	0	0	2	0	2
10:45 AM	4	1	0	0	5	0	0	0	0	0	0	0	2	0	2
Count Total	36	27	1	4	68	1	1	1	0	3	2	4	23	11	40
Peak Hour	13	9	0	0	22	0	1	1	0	2	1	0	6	4	11

Count Summaries - Heavy Vehicles																		
Interval Start	Orchard Ave				Orchard Ave				Joyce St				Joyce St				15-min Total	Rolling Hour Total
	Eastbound				Westbound				Northbound				Southbound					
	UT	LT	TH	RT	UT	LT	TH	RT	UT	LT	TH	RT	UT	LT	TH	RT		
7:00 AM	0	0	2	0	0	0	2	0	0	0	0	0	0	0	0	4	0	
7:15 AM	0	0	2	0	0	1	0	2	0	0	0	0	1	0	0	6	0	
7:30 AM	0	0	4	0	0	0	2	0	0	0	0	0	0	0	0	6	0	
7:45 AM	1	1	0	0	0	0	3	0	0	0	0	0	0	0	0	5	21	
8:00 AM	0	1	4	0	0	0	2	0	0	0	0	0	0	0	0	7	24	
8:15 AM	0	0	2	0	0	0	2	0	0	0	0	0	0	0	0	4	22	
8:30 AM	0	0	2	0	0	0	3	0	0	0	0	0	0	1	0	6	22	
8:45 AM	0	0	2	0	0	0	2	0	0	0	0	0	0	1	0	5	22	
9:00 AM	0	0	2	0	0	0	0	0	0	0	0	0	0	0	0	2	17	
9:15 AM	0	0	3	0	0	0	0	0	0	0	0	0	0	1	0	4	17	
9:30 AM	0	0	0	0	0	0	0	0	0	0	0	0	0	0	0	0	11	
9:45 AM	0	0	0	0	0	0	3	0	0	0	0	0	0	0	0	3	9	
10:00 AM	0	0	2	0	0	0	1	0	0	0	0	0	0	0	0	3	10	
10:15 AM	0	0	4	0	0	0	1	0	0	0	0	0	0	0	0	5	11	
10:30 AM	0	0	0	0	0	0	2	0	0	0	0	0	1	0	0	3	14	
10:45 AM	0	0	4	0	0	0	1	0	0	0	0	0	0	0	0	5	16	
Count Total	1	2	33	0	0	1	24	2	0	0	0	1	0	4	0	68		
Pk Hr Heavy	1	2	10	0	0	0	9	0	0	0	0	0	0	0	0	22		
Count Summaries - Bikes																		
Interval Start	Orchard Ave				Orchard Ave				Joyce St				Joyce St				15-min Total	Rolling Hour Total
	Eastbound				Westbound				Northbound				Southbound					
	UT	LT	TH	RT	UT	LT	TH	RT	UT	LT	TH	RT	UT	LT	TH	RT		
7:00 AM	0	0	0	0	0	0	0	0	0	0	0	0	0	0	0	0	0	
7:15 AM	0	0	0	0	0	0	0	0	0	0	0	0	0	0	0	0	0	
7:30 AM	0	0	0	0	0	0	1	0	0	0	0	0	0	0	0	1	0	
7:45 AM	0	0	0	0	0	0	0	0	0	0	0	0	0	0	0	0	1	
8:00 AM	0	0	0	0	0	0	0	0	0	0	0	0	0	0	0	0	1	
8:15 AM	0	0	0	0	0	0	0	0	0	0	1	0	0	0	0	1	2	
8:30 AM	0	0	0	0	0	0	0	0	0	0	0	0	0	0	0	0	1	
8:45 AM	0	0	0	0	0	0	0	0	0	0	0	0	0	0	0	0	1	
9:00 AM	0	0	0	1	0	0	0	0	0	0	0	0	0	0	0	1	2	
9:15 AM	0	0	0	0	0	0	0	0	0	0	0	0	0	0	0	0	1	
9:30 AM	0	0	0	0	0	0	0	0	0	0	0	0	0	0	0	0	1	
9:45 AM	0	0	0	0	0	0	0	0	0	0	0	0	0	0	0	0	1	
10:00 AM	0	0	0	0	0	0	0	0	0	0	0	0	0	0	0	0	0	
10:15 AM	0	0	0	0	0	0	0	0	0	0	0	0	0	0	0	0	0	
10:30 AM	0	0	0	0	0	0	0	0	0	0	0	0	0	0	0	0	0	
10:45 AM	0	0	0	0	0	0	0	0	0	0	0	0	0	0	0	0	0	
Count Total	0	0	0	1	0	0	1	0	0	0	1	0	0	0	0	3		
Pk Hr Bike	0	0	0	0	0	0	1	0	0	0	1	0	0	0	0	2		

Joyce St Orchard Ave



Peak Hour

Date: 2/15/2023
 Count Period: 11:00 AM to 3:00 PM
 Peak Hour: 1:15 PM to 2:15 PM

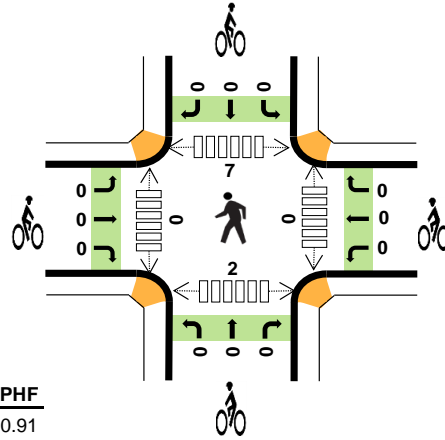
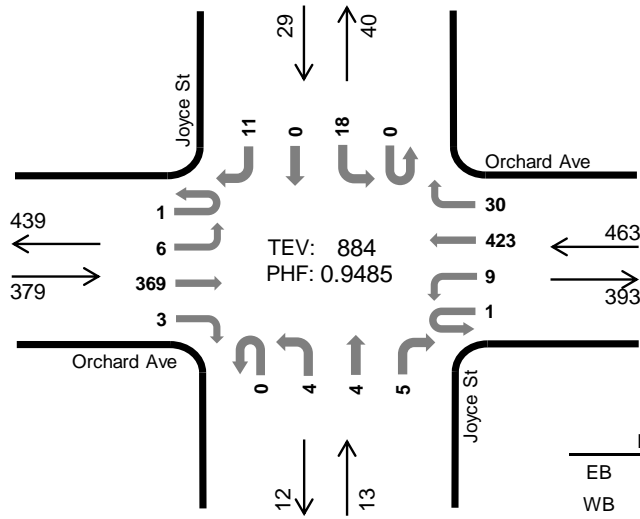

	HV%	PHF
EB	3%	0.91
WB	2%	0.87
NB	0%	0.65
SB	0%	0.73
TOTAL	3%	0.95

Peak Hour Count Summaries

Peak Hour Interval Start	Orchard Ave				Orchard Ave				Joyce St				Joyce St				15-min Total	Rolling Hour Total	
	Eastbound				Westbound				Northbound				Southbound						
	UT	LT	TH	RT	UT	LT	TH	RT	UT	LT	TH	RT	UT	LT	TH	RT			
1:15 PM	1	2	87	0	1	3	118	11	0	0	1	0	0	5	0	4	233	0	
1:30 PM	0	1	86	2	0	4	97	6	0	2	0	2	0	7	0	3	210	0	
1:45 PM	0	2	102	0	0	1	99	7	0	2	1	2	0	1	0	1	218	0	
2:00 PM	0	1	94	1	0	1	109	6	0	0	2	1	0	5	0	3	223	884	
Pk Hr	All	1	6	369	3	1	9	423	30	0	4	4	5	0	18	0	11	884	
	HV	0	0	12	0	0	1	9	1	0	0	0	0	0	0	0	0	23	
	HV%	0%	0%	3%	0%	0%	11%	2%	3%	-	0%	0%	0%	-	0%	-	0%	3%	

Note: For complete count summary (all intervals), see following pages.

** Heavy Vehicle Classifications include FHWA Classes 4-13.

** Count Summaries include heavy vehicles, but exclude bicycles in overall count.

Interval Start	Heavy Vehicle Totals					Bicycles					Pedestrians (Crossing Leg)				
	EB	WB	NB	SB	Total	EB	WB	NB	SB	Total	E	W	N	S	Total
1:15 PM	2	2	0	0	4	0	0	0	0	0	0	0	1	0	1
1:30 PM	3	3	0	0	6	0	0	0	0	0	0	0	1	0	1
1:45 PM	4	2	0	0	6	0	0	0	0	0	0	0	3	1	4
2:00 PM	3	4	0	0	7	0	0	0	0	0	0	0	2	1	3
Peak Hour	12	11	0	0	23	0	0	0	0	0	0	0	7	2	9

Count Summaries - All Vehicles

Interval Start	Orchard Ave				Orchard Ave				Joyce St				Joyce St				15-min Total	Rolling Hour Total	
	Eastbound				Westbound				Northbound				Southbound						
	UT	LT	TH	RT	UT	LT	TH	RT	UT	LT	TH	RT	UT	LT	TH	RT			
11:00 AM	0	1	57	0	0	1	86	3	0	1	0	1	0	5	0	2	157	0	
11:15 AM	0	2	43	0	1	2	81	3	0	0	0	1	0	4	0	3	140	0	
11:30 AM	0	0	67	0	1	3	69	6	0	1	0	2	0	3	0	3	155	0	
11:45 AM	0	1	68	1	0	2	84	8	0	3	0	2	0	3	0	1	173	625	
12:00 PM	0	0	79	2	2	0	73	2	0	1	0	3	0	1	2	3	168	636	
12:15 PM	0	3	73	1	2	3	100	4	0	1	0	0	0	3	0	2	192	688	
12:30 PM	0	0	83	3	2	1	104	4	0	2	0	1	0	5	0	4	209	742	
12:45 PM	0	1	79	0	0	1	92	6	0	1	1	0	0	4	1	3	189	758	
1:00 PM	0	2	79	0	1	2	89	7	0	0	0	1	0	2	0	2	185	775	
1:15 PM	1	2	87	0	1	3	118	11	0	0	1	0	0	5	0	4	233	816	
1:30 PM	0	1	86	2	0	4	97	6	0	2	0	2	0	7	0	3	210	817	
1:45 PM	0	2	102	0	0	1	99	7	0	2	1	2	0	1	0	1	218	846	
2:00 PM	0	1	94	1	0	1	109	6	0	0	2	1	0	5	0	3	223	884	
2:15 PM	1	1	76	1	0	0	90	5	0	0	1	2	0	4	0	2	183	834	
2:30 PM	0	4	79	2	1	2	88	6	0	1	0	1	1	6	0	1	192	816	
2:45 PM	0	6	83	1	1	0	98	5	0	3	0	2	0	3	0	5	207	805	
Count Total	2	27	1,235	14	12	26	1,477	89	0	18	6	21	1	61	3	42	3,034		
Pk Hr	All	1	6	369	3	1	9	423	30	0	4	4	5	0	18	0	11	884	
	HV	0	0	12	0	0	1	9	1	0	0	0	0	0	0	0	0	23	
	HV%	0%	0%	3%	0%	0%	11%	2%	3%	-	0%	0%	0%	-	0%	-	0%	3%	

Interval Start	Heavy Vehicle Totals					Bicycles					Pedestrians (Crossing Leg)				
	EB	WB	NB	SB	Total	EB	WB	NB	SB	Total	E	W	N	S	Total
11:00 AM	2	5	1	0	8	0	0	0	0	0	0	1	5	1	7
11:15 AM	1	3	0	1	5	0	0	0	0	0	0	0	1	1	2
11:30 AM	0	6	0	0	6	0	0	0	0	0	0	1	1	1	3
11:45 AM	2	1	0	0	3	0	0	0	0	0	0	0	2	1	3
12:00 PM	3	2	0	0	5	0	0	0	0	0	0	0	0	0	0
12:15 PM	2	1	0	0	3	0	0	0	0	0	0	1	4	1	6
12:30 PM	6	4	0	0	10	0	0	0	0	0	0	0	0	0	0
12:45 PM	2	1	1	0	4	0	0	0	0	0	0	0	0	0	0
1:00 PM	0	1	0	0	1	0	0	0	0	0	0	1	4	1	6
1:15 PM	2	2	0	0	4	0	0	0	0	0	0	0	1	0	1
1:30 PM	3	3	0	0	6	0	0	0	0	0	0	0	1	0	1
1:45 PM	4	2	0	0	6	0	0	0	0	0	0	0	3	1	4
2:00 PM	3	4	0	0	7	0	0	0	0	0	0	0	2	1	3
2:15 PM	1	4	0	0	5	0	1	0	0	1	0	0	3	1	4
2:30 PM	0	3	0	0	3	0	0	0	0	0	0	0	1	0	1
2:45 PM	0	0	0	0	0	0	0	0	0	0	0	1	0	0	1
Count Total	31	42	2	1	76	0	1	0	0	1	0	5	28	9	42
Peak Hour	12	11	0	0	23	0	0	0	0	0	0	0	7	2	9

Count Summaries - Heavy Vehicles																		
Interval Start	Orchard Ave				Orchard Ave				Joyce St				Joyce St				15-min Total	Rolling Hour Total
	Eastbound				Westbound				Northbound				Southbound					
	UT	LT	TH	RT	UT	LT	TH	RT	UT	LT	TH	RT	UT	LT	TH	RT		
11:00 AM	0	0	2	0	0	0	4	1	0	0	0	1	0	0	0	0	8	0
11:15 AM	0	0	1	0	0	0	3	0	0	0	0	0	0	0	0	1	5	0
11:30 AM	0	0	0	0	0	0	6	0	0	0	0	0	0	0	0	0	6	0
11:45 AM	0	0	2	0	0	0	1	0	0	0	0	0	0	0	0	0	3	22
12:00 PM	0	0	3	0	0	0	2	0	0	0	0	0	0	0	0	0	5	19
12:15 PM	0	0	2	0	0	0	1	0	0	0	0	0	0	0	0	0	3	17
12:30 PM	0	0	6	0	0	0	2	2	0	0	0	0	0	0	0	0	10	21
12:45 PM	0	0	2	0	0	0	1	0	0	0	1	0	0	0	0	0	4	22
1:00 PM	0	0	0	0	0	0	1	0	0	0	0	0	0	0	0	0	1	18
1:15 PM	0	0	2	0	0	0	1	1	0	0	0	0	0	0	0	0	4	19
1:30 PM	0	0	3	0	0	1	2	0	0	0	0	0	0	0	0	0	6	15
1:45 PM	0	0	4	0	0	0	2	0	0	0	0	0	0	0	0	0	6	17
2:00 PM	0	0	3	0	0	0	4	0	0	0	0	0	0	0	0	0	7	23
2:15 PM	0	0	1	0	0	0	4	0	0	0	0	0	0	0	0	0	5	24
2:30 PM	0	0	0	0	0	0	3	0	0	0	0	0	0	0	0	0	3	21
2:45 PM	0	0	0	0	0	0	0	0	0	0	0	0	0	0	0	0	0	15
Count Total	0	0	31	0	0	1	37	4	0	0	1	1	0	0	0	1	76	
Pk Hr Heavy	0	0	12	0	0	1	9	1	0	0	0	0	0	0	0	0	23	

Count Summaries - Bikes																		
Interval Start	Orchard Ave				Orchard Ave				Joyce St				Joyce St				15-min Total	Rolling Hour Total
	Eastbound				Westbound				Northbound				Southbound					
	UT	LT	TH	RT	UT	LT	TH	RT	UT	LT	TH	RT	UT	LT	TH	RT		
11:00 AM	0	0	0	0	0	0	0	0	0	0	0	0	0	0	0	0	0	0
11:15 AM	0	0	0	0	0	0	0	0	0	0	0	0	0	0	0	0	0	0
11:30 AM	0	0	0	0	0	0	0	0	0	0	0	0	0	0	0	0	0	0
11:45 AM	0	0	0	0	0	0	0	0	0	0	0	0	0	0	0	0	0	0
12:00 PM	0	0	0	0	0	0	0	0	0	0	0	0	0	0	0	0	0	0
12:15 PM	0	0	0	0	0	0	0	0	0	0	0	0	0	0	0	0	0	0
12:30 PM	0	0	0	0	0	0	0	0	0	0	0	0	0	0	0	0	0	0
12:45 PM	0	0	0	0	0	0	0	0	0	0	0	0	0	0	0	0	0	0
1:00 PM	0	0	0	0	0	0	0	0	0	0	0	0	0	0	0	0	0	0
1:15 PM	0	0	0	0	0	0	0	0	0	0	0	0	0	0	0	0	0	0
1:30 PM	0	0	0	0	0	0	0	0	0	0	0	0	0	0	0	0	0	0
1:45 PM	0	0	0	0	0	0	0	0	0	0	0	0	0	0	0	0	0	0
2:00 PM	0	0	0	0	0	0	0	0	0	0	0	0	0	0	0	0	0	0
2:15 PM	0	0	0	0	0	0	1	0	0	0	0	0	0	0	0	0	1	1
2:30 PM	0	0	0	0	0	0	0	0	0	0	0	0	0	0	0	0	0	1
2:45 PM	0	0	0	0	0	0	0	0	0	0	0	0	0	0	0	0	0	1
Count Total	0	0	0	0	0	0	1	0	0	0	0	0	0	0	0	0	1	
Pk Hr Bike	0	0	0	0	0	0	0	0	0	0	0	0	0	0	0	0	0	

Joyce St Orchard Ave



Peak Hour

Date: 2/15/2023
 Count Period: 3:00 PM to 7:00 PM
 Peak Hour: 4:45 PM to 5:45 PM

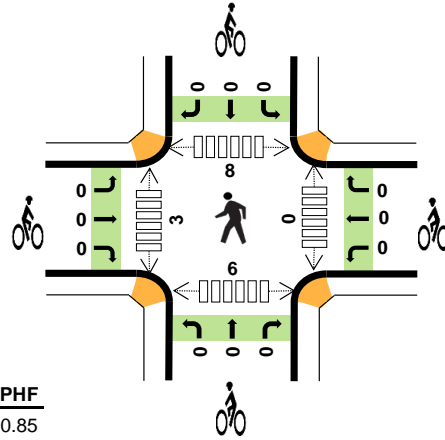
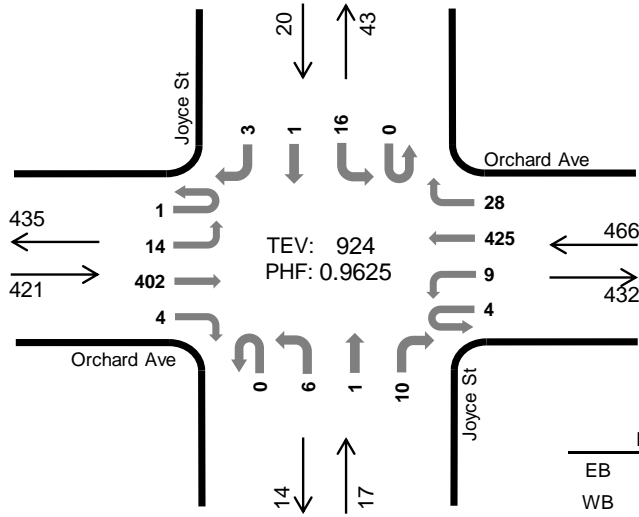

	HV%	PHF
EB	0%	0.85
WB	1%	0.88
NB	0%	0.85
SB	0%	0.71
TOTAL	1%	0.96

Peak Hour Count Summaries

Peak Hour Interval Start	Orchard Ave				Orchard Ave				Joyce St				Joyce St				15-min Total	Rolling Hour Total	
	Eastbound		Westbound		Northbound		Southbound		Northbound		Southbound								
	UT	LT	TH	RT	UT	LT	TH	RT	UT	LT	TH	RT	UT	LT	TH	RT			
4:45 PM	0	3	83	0	1	0	114	7	0	1	0	2	0	7	0	0	218	0	
5:00 PM	0	4	92	2	1	3	119	9	0	2	1	2	0	4	0	1	240	0	
5:15 PM	1	2	121	0	1	4	88	8	0	2	0	3	0	3	0	1	234	0	
5:30 PM	0	5	106	2	1	2	104	4	0	1	0	3	0	2	1	1	232	924	
Pk Hr	All	1	14	402	4	4	9	425	28	0	6	1	10	0	16	1	3	924	
	HV	0	0	2	0	0	0	4	0	0	0	0	0	0	0	0	0	6	
	HV%	0%	0%	0%	0%	0%	0%	1%	0%	-	0%	0%	0%	-	0%	0%	0%	1%	

Note: For complete count summary (all intervals), see following pages.

** Heavy Vehicle Classifications include FHWA Classes 4-13.

** Count Summaries include heavy vehicles, but exclude bicycles in overall count.

Interval Start	Heavy Vehicle Totals					Bicycles				Pedestrians (Crossing Leg)					
	EB	WB	NB	SB	Total	EB	WB	NB	SB	Total	E	W	N	S	Total
4:45 PM	0	1	0	0	1	0	0	0	0	0	0	0	1	2	3
5:00 PM	1	2	0	0	3	0	0	0	0	0	0	1	1	2	4
5:15 PM	0	0	0	0	0	0	0	0	0	0	0	0	6	1	7
5:30 PM	1	1	0	0	2	0	0	0	0	0	0	2	0	1	3
Peak Hour	2	4	0	0	6	0	0	0	0	0	0	3	8	6	17

Count Summaries - All Vehicles

Interval Start	Orchard Ave				Orchard Ave				Joyce St				Joyce St				15-min Total	Rolling Hour Total	
	Eastbound				Westbound				Northbound				Southbound						
	UT	LT	TH	RT	UT	LT	TH	RT	UT	LT	TH	RT	UT	LT	TH	RT			
3:00 PM	0	2	86	1	1	1	90	4	0	0	0	1	0	4	1	2	193	0	
3:15 PM	1	2	94	0	1	0	118	10	0	0	2	2	0	1	0	2	233	0	
3:30 PM	0	0	84	4	0	3	117	3	0	1	0	1	0	1	1	5	220	0	
3:45 PM	1	1	89	3	1	1	85	7	0	1	1	1	0	8	0	2	201	847	
4:00 PM	0	5	105	0	1	0	111	10	0	1	0	0	0	4	0	0	237	891	
4:15 PM	0	3	90	2	0	3	102	5	0	2	0	0	0	3	1	3	214	872	
4:30 PM	0	2	95	0	0	0	113	5	0	0	2	1	0	6	0	0	224	876	
4:45 PM	0	3	83	0	1	0	114	7	0	1	0	2	0	7	0	0	218	893	
5:00 PM	0	4	92	2	1	3	119	9	0	2	1	2	0	4	0	1	240	896	
5:15 PM	1	2	121	0	1	4	88	8	0	2	0	3	0	3	0	1	234	916	
5:30 PM	0	5	106	2	1	2	104	4	0	1	0	3	0	2	1	1	232	924	
5:45 PM	0	2	93	4	1	4	96	5	0	1	2	2	0	3	0	1	214	920	
6:00 PM	4	3	116	1	1	0	97	3	0	0	0	0	0	1	0	3	229	909	
6:15 PM	1	1	101	0	3	0	90	5	0	0	0	1	0	4	0	3	209	884	
6:30 PM	1	3	99	0	0	2	103	3	0	1	0	2	0	5	0	2	221	873	
6:45 PM	1	7	99	0	0	3	63	4	1	0	0	2	0	6	0	2	188	847	
Count Total	10	45	1,553	19	13	26	1,610	92	1	13	8	23	0	62	4	28	3,507		
Pk Hr	All	1	14	402	4	4	9	425	28	0	6	1	10	0	16	1	3	924	
	HV	0	0	2	0	0	0	4	0	0	0	0	0	0	0	0	0	6	
	HV%	0%	0%	0%	0%	0%	0%	1%	0%	-	0%	0%	0%	-	0%	0%	0%	1%	

Interval Start	Heavy Vehicle Totals					Bicycles					Pedestrians (Crossing Leg)				
	EB	WB	NB	SB	Total	EB	WB	NB	SB	Total	E	W	N	S	Total
3:00 PM	1	0	0	0	1	0	0	0	0	0	0	0	0	2	2
3:15 PM	1	3	0	1	5	0	0	0	0	0	0	0	1	1	2
3:30 PM	0	2	0	1	3	0	0	0	0	0	0	0	1	0	1
3:45 PM	2	2	0	0	4	0	0	0	0	0	0	0	4	2	6
4:00 PM	4	3	0	0	7	0	0	0	0	0	0	0	2	1	3
4:15 PM	0	2	0	0	2	0	0	0	0	0	0	0	3	1	4
4:30 PM	0	1	0	0	1	0	0	0	0	0	0	0	3	0	3
4:45 PM	0	1	0	0	1	0	0	0	0	0	0	0	1	2	3
5:00 PM	1	2	0	0	3	0	0	0	0	0	0	1	1	2	4
5:15 PM	0	0	0	0	0	0	0	0	0	0	0	0	6	1	7
5:30 PM	1	1	0	0	2	0	0	0	0	0	0	2	0	1	3
5:45 PM	0	1	0	0	1	0	0	0	0	0	0	0	5	2	7
6:00 PM	0	4	0	0	4	0	0	0	0	0	0	0	3	0	3
6:15 PM	3	0	0	1	4	0	0	0	0	0	0	0	1	1	2
6:30 PM	1	1	0	0	2	0	0	0	0	0	0	0	0	1	1
6:45 PM	0	1	0	0	1	0	0	0	0	0	0	1	4	1	6
Count Total	14	24	0	3	41	0	0	0	0	0	0	4	35	18	57
Peak Hour	2	4	0	0	6	0	0	0	0	0	0	3	8	6	17

Count Summaries - Heavy Vehicles																		
Interval Start	Orchard Ave				Orchard Ave				Joyce St				Joyce St				15-min Total	Rolling Hour Total
	Eastbound				Westbound				Northbound				Southbound					
	UT	LT	TH	RT	UT	LT	TH	RT	UT	LT	TH	RT	UT	LT	TH	RT		
3:00 PM	0	0	1	0	0	0	0	0	0	0	0	0	0	0	0	1	0	
3:15 PM	0	0	1	0	0	0	2	1	0	0	0	0	0	0	0	5	0	
3:30 PM	0	0	0	0	0	0	1	1	0	0	0	0	0	0	0	3	0	
3:45 PM	0	0	0	2	0	0	2	0	0	0	0	0	0	0	0	4	13	
4:00 PM	0	0	4	0	0	0	3	0	0	0	0	0	0	0	0	7	19	
4:15 PM	0	0	0	0	0	0	2	0	0	0	0	0	0	0	0	2	16	
4:30 PM	0	0	0	0	0	0	1	0	0	0	0	0	0	0	0	1	14	
4:45 PM	0	0	0	0	0	0	1	0	0	0	0	0	0	0	0	1	11	
5:00 PM	0	0	1	0	0	0	2	0	0	0	0	0	0	0	0	3	7	
5:15 PM	0	0	0	0	0	0	0	0	0	0	0	0	0	0	0	0	5	
5:30 PM	0	0	1	0	0	0	1	0	0	0	0	0	0	0	0	2	6	
5:45 PM	0	0	0	0	0	0	1	0	0	0	0	0	0	0	0	1	6	
6:00 PM	0	0	0	0	0	0	3	1	0	0	0	0	0	0	0	4	7	
6:15 PM	0	0	3	0	0	0	0	0	0	0	0	0	0	0	1	4	11	
6:30 PM	0	0	1	0	0	0	1	0	0	0	0	0	0	0	0	2	11	
6:45 PM	0	0	0	0	0	0	1	0	0	0	0	0	0	0	0	1	11	
Count Total	0	0	12	2	0	0	21	3	0	0	0	0	0	0	3	41		
Pk Hr Heavy	0	0	2	0	0	0	4	0	0	0	0	0	0	0	0	6		

Count Summaries - Bikes																		
Interval Start	Orchard Ave				Orchard Ave				Joyce St				Joyce St				15-min Total	Rolling Hour Total
	Eastbound				Westbound				Northbound				Southbound					
	UT	LT	TH	RT	UT	LT	TH	RT	UT	LT	TH	RT	UT	LT	TH	RT		
3:00 PM	0	0	0	0	0	0	0	0	0	0	0	0	0	0	0	0	0	
3:15 PM	0	0	0	0	0	0	0	0	0	0	0	0	0	0	0	0	0	
3:30 PM	0	0	0	0	0	0	0	0	0	0	0	0	0	0	0	0	0	
3:45 PM	0	0	0	0	0	0	0	0	0	0	0	0	0	0	0	0	0	
4:00 PM	0	0	0	0	0	0	0	0	0	0	0	0	0	0	0	0	0	
4:15 PM	0	0	0	0	0	0	0	0	0	0	0	0	0	0	0	0	0	
4:30 PM	0	0	0	0	0	0	0	0	0	0	0	0	0	0	0	0	0	
4:45 PM	0	0	0	0	0	0	0	0	0	0	0	0	0	0	0	0	0	
5:00 PM	0	0	0	0	0	0	0	0	0	0	0	0	0	0	0	0	0	
5:15 PM	0	0	0	0	0	0	0	0	0	0	0	0	0	0	0	0	0	
5:30 PM	0	0	0	0	0	0	0	0	0	0	0	0	0	0	0	0	0	
5:45 PM	0	0	0	0	0	0	0	0	0	0	0	0	0	0	0	0	0	
6:00 PM	0	0	0	0	0	0	0	0	0	0	0	0	0	0	0	0	0	
6:15 PM	0	0	0	0	0	0	0	0	0	0	0	0	0	0	0	0	0	
6:30 PM	0	0	0	0	0	0	0	0	0	0	0	0	0	0	0	0	0	
6:45 PM	0	0	0	0	0	0	0	0	0	0	0	0	0	0	0	0	0	
Count Total	0	0	0	0	0	0	0	0	0	0	0	0	0	0	0	0		
Pk Hr Bike	0	0	0	0	0	0	0	0	0	0	0	0	0	0	0	0		

Mission Blvd Orchard Ave

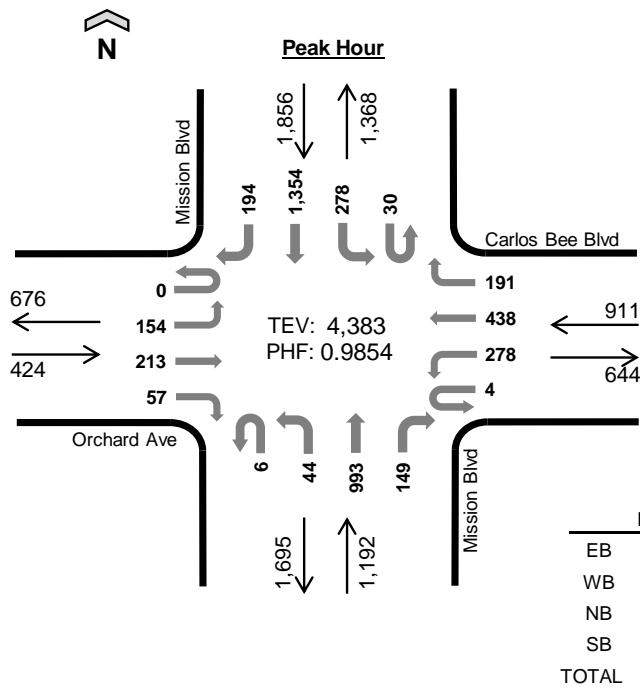

Date: 2/15/2023
Count Period: 7:00 AM to 11:00 AM
Peak Hour: 7:30 AM to 8:30 AM

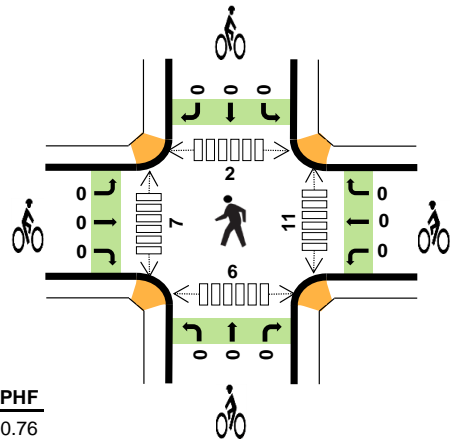

Peak Hour Count Summaries

Peak Hour Interval Start	Orchard Ave				Carlos Bee Blvd				Mission Blvd				Mission Blvd				15-min Total	Rolling Hour Total	
	Eastbound		Westbound		Northbound		Southbound		Northbound		Southbound								
	UT	LT	TH	RT	UT	LT	TH	RT	UT	LT	TH	RT	UT	LT	TH	RT			
7:30 AM	0	25	42	21	0	77	100	48	0	4	223	23	5	55	419	49	1,091	0	
7:45 AM	0	40	55	9	0	68	132	31	1	14	249	40	7	86	297	60	1,089	0	
8:00 AM	0	52	69	19	0	55	83	44	3	14	283	56	5	73	307	49	1,112	0	
8:15 AM	0	37	47	8	4	78	123	68	2	12	238	30	13	64	331	36	1,091	4,383	
Pk Hr	All	0	154	213	57	4	278	438	191	6	44	993	149	30	278	1,354	194	4,383	
	HV	0	4	3	4	0	2	6	2	0	2	27	6	1	6	36	4	103	
	HV%	-	3%	1%	7%	0%	1%	1%	1%	0%	5%	3%	4%	3%	2%	3%	2%	2%	

Note: For complete count summary (all intervals), see following pages.

** Heavy Vehicle Classifications include FHWA Classes 4-13.

** Count Summaries include heavy vehicles, but exclude bicycles in overall count.

Interval Start	Heavy Vehicle Totals					Bicycles				Pedestrians (Crossing Leg)					
	EB	WB	NB	SB	Total	EB	WB	NB	SB	Total	E	W	N	S	Total
7:30 AM	4	1	11	14	30	0	0	0	0	0	3	1	1	1	6
7:45 AM	0	2	9	12	23	0	0	0	0	0	3	2	1	1	7
8:00 AM	3	1	6	8	18	0	0	0	0	0	1	3	0	0	4
8:15 AM	4	6	9	13	32	0	0	0	0	0	4	1	0	4	9
Peak Hour	11	10	35	47	103	0	0	0	0	0	11	7	2	6	26

Count Summaries - All Vehicles

Interval Start	Orchard Ave				Carlos Bee Blvd				Mission Blvd				Mission Blvd				15-min Total	Rolling Hour Total	
	Eastbound				Westbound				Northbound				Southbound						
	UT	LT	TH	RT	UT	LT	TH	RT	UT	LT	TH	RT	UT	LT	TH	RT			
7:00 AM	0	24	16	18	0	84	64	44	1	12	160	19	3	23	370	19	857	0	
7:15 AM	0	32	14	14	0	82	81	50	0	7	232	12	7	33	465	40	1,069	0	
7:30 AM	0	25	42	21	0	77	100	48	0	4	223	23	5	55	419	49	1,091	0	
7:45 AM	0	40	55	9	0	68	132	31	1	14	249	40	7	86	297	60	1,089	4,106	
8:00 AM	0	52	69	19	0	55	83	44	3	14	283	56	5	73	307	49	1,112	4,361	
8:15 AM	0	37	47	8	4	78	123	68	2	12	238	30	13	64	331	36	1,091	4,383	
8:30 AM	0	43	49	11	4	61	98	74	2	21	210	34	22	55	346	30	1,060	4,352	
8:45 AM	0	21	45	8	3	55	89	59	2	12	199	18	14	65	320	31	941	4,204	
9:00 AM	0	14	40	10	2	43	56	32	7	6	188	31	8	103	311	21	872	3,964	
9:15 AM	0	17	47	9	1	51	55	55	2	7	156	21	9	107	313	12	862	3,735	
9:30 AM	0	16	37	10	0	36	56	45	3	11	149	25	13	79	243	18	741	3,416	
9:45 AM	0	10	32	7	0	37	65	35	2	6	144	24	4	103	274	16	759	3,234	
10:00 AM	0	17	37	14	0	41	42	44	3	6	159	22	8	47	269	33	742	3,104	
10:15 AM	0	11	30	6	0	31	52	31	4	9	182	20	4	69	256	21	726	2,968	
10:30 AM	0	10	31	8	1	38	65	41	4	8	154	16	4	112	223	20	735	2,962	
10:45 AM	0	15	44	10	0	38	56	73	4	17	145	18	7	114	245	16	802	3,005	
Count Total	0	384	635	182	15	875	1,217	774	40	166	3,071	409	133	1,188	4,989	471	14,549		
Pk Hr	All	0	154	213	57	4	278	438	191	6	44	993	149	30	278	1,354	194	4,383	
	HV	0	4	3	4	0	2	6	2	0	2	27	6	1	6	36	4	103	
	HV%	-	3%	1%	7%	0%	1%	1%	1%	0%	5%	3%	4%	3%	2%	3%	2%	2%	

Interval Start	Heavy Vehicle Totals					Bicycles					Pedestrians (Crossing Leg)				
	EB	WB	NB	SB	Total	EB	WB	NB	SB	Total	E	W	N	S	Total
7:00 AM	2	0	3	8	13	0	0	0	0	0	1	2	5	0	8
7:15 AM	2	1	6	21	30	0	0	0	0	0	2	0	0	0	2
7:30 AM	4	1	11	14	30	0	0	0	0	0	3	1	1	1	6
7:45 AM	0	2	9	12	23	0	0	0	0	0	3	2	1	1	7
8:00 AM	3	1	6	8	18	0	0	0	0	0	1	3	0	0	4
8:15 AM	4	6	9	13	32	0	0	0	0	0	4	1	0	4	9
8:30 AM	3	4	10	12	29	0	0	0	0	0	0	2	0	0	2
8:45 AM	5	5	13	15	38	0	0	0	0	0	3	1	2	0	6
9:00 AM	4	1	9	17	31	0	0	0	0	0	1	0	2	0	3
9:15 AM	3	6	6	8	23	0	0	0	0	0	2	1	1	1	5
9:30 AM	0	2	9	16	27	0	0	0	0	0	0	3	1	0	4
9:45 AM	1	3	5	10	19	0	0	0	0	0	0	1	1	0	2
10:00 AM	5	0	9	18	32	0	0	0	0	0	0	1	0	0	1
10:15 AM	6	2	6	13	27	0	0	0	0	0	0	4	0	0	4
10:30 AM	2	4	6	10	22	0	0	0	0	0	2	1	0	0	3
10:45 AM	3	3	11	17	34	0	0	0	0	0	0	1	0	0	1
Count Total	47	41	128	212	428	0	0	0	0	0	22	24	14	7	67
Peak Hour	11	10	35	47	103	0	0	0	0	0	11	7	2	6	26

Count Summaries - Heavy Vehicles																		
Interval Start	Orchard Ave				Carlos Bee Blvd				Mission Blvd				Mission Blvd				15-min Total	Rolling Hour Total
	Eastbound				Westbound				Northbound				Southbound					
	UT	LT	TH	RT	UT	LT	TH	RT	UT	LT	TH	RT	UT	LT	TH	RT		
7:00 AM	0	1	0	1	0	0	0	0	0	0	2	1	0	2	6	0	13	0
7:15 AM	0	1	0	1	0	0	0	1	0	0	6	0	1	1	15	4	30	0
7:30 AM	0	1	0	3	0	1	0	0	0	1	8	2	0	3	10	1	30	0
7:45 AM	0	0	0	0	0	0	2	0	0	1	7	1	0	1	10	1	23	96
8:00 AM	0	1	2	0	0	0	1	0	0	0	5	1	1	0	5	2	18	101
8:15 AM	0	2	1	1	0	1	3	2	0	0	7	2	0	2	11	0	32	103
8:30 AM	0	3	0	0	0	1	2	1	0	1	9	0	0	2	10	0	29	102
8:45 AM	0	2	1	2	0	0	2	3	0	2	11	0	0	1	12	2	38	117
9:00 AM	0	1	3	0	0	0	0	1	0	1	7	1	0	4	13	0	31	130
9:15 AM	0	2	1	0	0	1	0	5	0	0	6	0	0	0	8	0	23	121
9:30 AM	0	0	0	0	0	0	0	2	0	0	8	1	1	1	14	0	27	119
9:45 AM	0	0	1	0	0	0	2	1	0	0	5	0	0	1	8	1	19	100
10:00 AM	0	3	2	0	0	0	0	0	0	0	7	2	0	0	15	3	32	101
10:15 AM	0	2	3	1	0	1	1	0	0	0	6	0	1	1	10	1	27	105
10:30 AM	0	0	1	1	0	1	1	2	0	0	5	1	0	1	9	0	22	100
10:45 AM	0	1	2	0	0	0	0	3	0	0	10	1	0	1	15	1	34	115
Count Total	0	20	17	10	0	6	14	21	0	6	109	13	4	21	171	16	428	
Pk Hr Heavy	0	4	3	4	0	2	6	2	0	2	27	6	1	6	36	4	103	
Count Summaries - Bikes																		
Interval Start	Orchard Ave				Carlos Bee Blvd				Mission Blvd				Mission Blvd				15-min Total	Rolling Hour Total
	Eastbound				Westbound				Northbound				Southbound					
	UT	LT	TH	RT	UT	LT	TH	RT	UT	LT	TH	RT	UT	LT	TH	RT		
7:00 AM	0	0	0	0	0	0	0	0	0	0	0	0	0	0	0	0	0	0
7:15 AM	0	0	0	0	0	0	0	0	0	0	0	0	0	0	0	0	0	0
7:30 AM	0	0	0	0	0	0	0	0	0	0	0	0	0	0	0	0	0	0
7:45 AM	0	0	0	0	0	0	0	0	0	0	0	0	0	0	0	0	0	0
8:00 AM	0	0	0	0	0	0	0	0	0	0	0	0	0	0	0	0	0	0
8:15 AM	0	0	0	0	0	0	0	0	0	0	0	0	0	0	0	0	0	0
8:30 AM	0	0	0	0	0	0	0	0	0	0	0	0	0	0	0	0	0	0
8:45 AM	0	0	0	0	0	0	0	0	0	0	0	0	0	0	0	0	0	0
9:00 AM	0	0	0	0	0	0	0	0	0	0	0	0	0	0	0	0	0	0
9:15 AM	0	0	0	0	0	0	0	0	0	0	0	0	0	0	0	0	0	0
9:30 AM	0	0	0	0	0	0	0	0	0	0	0	0	0	0	0	0	0	0
9:45 AM	0	0	0	0	0	0	0	0	0	0	0	0	0	0	0	0	0	0
10:00 AM	0	0	0	0	0	0	0	0	0	0	0	0	0	0	0	0	0	0
10:15 AM	0	0	0	0	0	0	0	0	0	0	0	0	0	0	0	0	0	0
10:30 AM	0	0	0	0	0	0	0	0	0	0	0	0	0	0	0	0	0	0
10:45 AM	0	0	0	0	0	0	0	0	0	0	0	0	0	0	0	0	0	0
Count Total	0	0	0	0	0	0	0	0	0	0	0	0	0	0	0	0	0	
Pk Hr Bike	0	0	0	0	0	0	0	0	0	0	0	0	0	0	0	0	0	

Mission Blvd Orchard Ave



Peak Hour

Date: 2/15/2023
 Count Period: 11:00 AM to 3:00 PM
 Peak Hour: 1:15 PM to 2:15 PM

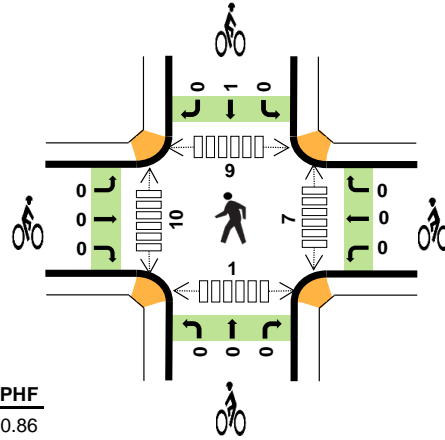
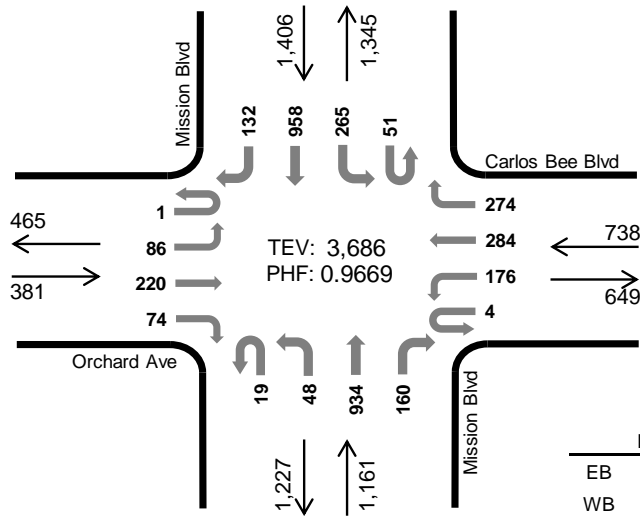

	HV%	PHF
EB	2%	0.86
WB	1%	0.82
NB	2%	0.89
SB	3%	0.89
TOTAL	2%	0.97

Peak Hour Count Summaries

Peak Hour Interval Start	Orchard Ave				Carlos Bee Blvd				Mission Blvd				Mission Blvd				15-min Total	Rolling Hour Total	
	Eastbound		Westbound		Northbound		Southbound		Northbound		Southbound								
	UT	LT	TH	RT	UT	LT	TH	RT	UT	LT	TH	RT	UT	LT	TH	RT			
1:15 PM	0	24	64	23	1	61	92	71	4	16	206	34	13	50	231	33	923	0	
1:30 PM	1	21	47	13	1	48	61	68	8	12	229	35	8	66	254	34	906	0	
1:45 PM	0	9	57	18	0	23	68	60	2	9	274	40	11	99	253	30	953	0	
2:00 PM	0	32	52	20	2	44	63	75	5	11	225	51	19	50	220	35	904	3,686	
Pk Hr	All	1	86	220	74	4	176	284	274	19	48	934	160	51	265	958	132	3,686	
	HV	0	1	6	2	0	4	3	2	2	2	21	3	0	2	38	3	89	
	HV%	0%	1%	3%	3%	0%	2%	1%	1%	11%	4%	2%	2%	0%	1%	4%	2%	2%	

Note: For complete count summary (all intervals), see following pages.

** Heavy Vehicle Classifications include FHWA Classes 4-13.

** Count Summaries include heavy vehicles, but exclude bicycles in overall count.

Interval Start	Heavy Vehicle Totals					Bicycles					Pedestrians (Crossing Leg)				
	EB	WB	NB	SB	Total	EB	WB	NB	SB	Total	E	W	N	S	Total
1:15 PM	2	3	4	17	26	0	0	0	0	0	0	3	3	0	6
1:30 PM	1	2	6	15	24	0	0	0	0	0	4	2	0	0	6
1:45 PM	3	1	8	5	17	0	0	0	0	0	0	0	2	0	2
2:00 PM	3	3	10	6	22	0	0	0	1	1	3	5	4	1	13
Peak Hour	9	9	28	43	89	0	0	0	1	1	7	10	9	1	27

Count Summaries - All Vehicles

Interval Start	Orchard Ave				Carlos Bee Blvd				Mission Blvd				Mission Blvd				15-min Total	Rolling Hour Total	
	Eastbound				Westbound				Northbound				Southbound						
	UT	LT	TH	RT	UT	LT	TH	RT	UT	LT	TH	RT	UT	LT	TH	RT			
11:00 AM	0	16	26	16	0	31	55	76	3	8	152	21	7	65	198	21	695	0	
11:15 AM	0	12	29	9	1	30	48	47	4	15	148	17	11	54	219	26	670	0	
11:30 AM	0	13	42	12	1	40	45	74	2	12	164	30	4	43	197	19	698	0	
11:45 AM	0	23	36	7	1	33	53	85	6	12	167	23	14	55	197	25	737	2,800	
12:00 PM	0	15	55	12	0	46	45	61	4	11	184	33	15	57	187	20	745	2,850	
12:15 PM	0	14	47	14	0	27	61	101	3	21	200	45	11	63	208	34	849	3,029	
12:30 PM	1	20	58	23	1	42	68	73	3	18	197	46	5	50	179	31	815	3,146	
12:45 PM	0	15	55	9	0	35	54	58	5	10	204	47	15	48	195	31	781	3,190	
1:00 PM	0	18	56	8	0	28	57	37	3	14	207	36	17	48	212	29	770	3,215	
1:15 PM	0	24	64	23	1	61	92	71	4	16	206	34	13	50	231	33	923	3,289	
1:30 PM	1	21	47	13	1	48	61	68	8	12	229	35	8	66	254	34	906	3,380	
1:45 PM	0	9	57	18	0	23	68	60	2	9	274	40	11	99	253	30	953	3,552	
2:00 PM	0	32	52	20	2	44	63	75	5	11	225	51	19	50	220	35	904	3,686	
2:15 PM	0	29	41	12	2	52	46	54	6	14	279	59	14	35	218	30	891	3,654	
2:30 PM	2	21	45	15	0	43	56	33	7	14	276	69	11	42	221	32	887	3,635	
2:45 PM	0	26	38	8	0	31	48	31	7	20	220	60	14	38	209	35	785	3,467	
Count Total	4	308	748	219	10	614	920	1,004	72	217	3,332	646	189	863	3,398	465	13,009		
Pk Hr	All	1	86	220	74	4	176	284	274	19	48	934	160	51	265	958	132	3,686	
	HV	0	1	6	2	0	4	3	2	2	2	21	3	0	2	38	3	89	
	HV%	0%	1%	3%	3%	0%	2%	1%	1%	11%	4%	2%	2%	0%	1%	4%	2%	2%	

Interval Start	Heavy Vehicle Totals					Bicycles					Pedestrians (Crossing Leg)				
	EB	WB	NB	SB	Total	EB	WB	NB	SB	Total	E	W	N	S	Total
11:00 AM	4	4	11	9	28	0	0	0	0	0	1	0	0	0	1
11:15 AM	1	1	11	17	30	0	0	0	1	1	1	7	2	0	10
11:30 AM	1	6	7	10	24	0	0	0	0	0	1	3	1	1	6
11:45 AM	2	1	2	5	10	0	0	0	0	0	0	1	1	0	2
12:00 PM	1	2	5	9	17	0	0	0	1	1	1	3	1	0	5
12:15 PM	6	2	8	14	30	0	0	0	0	0	2	0	2	1	5
12:30 PM	6	3	10	6	25	0	0	0	0	0	2	1	1	0	4
12:45 PM	3	0	8	10	21	0	0	0	0	0	0	0	1	0	1
1:00 PM	1	2	10	8	21	0	0	0	1	1	0	3	1	0	4
1:15 PM	2	3	4	17	26	0	0	0	0	0	0	3	3	0	6
1:30 PM	1	2	6	15	24	0	0	0	0	0	4	2	0	0	6
1:45 PM	3	1	8	5	17	0	0	0	0	0	0	0	2	0	2
2:00 PM	3	3	10	6	22	0	0	0	1	1	3	5	4	1	13
2:15 PM	1	3	7	15	26	0	0	1	0	1	2	3	2	0	7
2:30 PM	1	3	7	7	18	0	1	0	0	1	1	5	5	0	11
2:45 PM	0	2	6	4	12	0	0	0	0	0	1	3	2	0	6
Count Total	36	38	120	157	351	0	1	1	4	6	19	39	28	3	89
Peak Hour	9	9	28	43	89	0	0	0	1	1	7	10	9	1	27

Count Summaries - Heavy Vehicles																		
Interval Start	Orchard Ave				Carlos Bee Blvd				Mission Blvd				Mission Blvd				15-min Total	Rolling Hour Total
	Eastbound				Westbound				Northbound				Southbound					
	UT	LT	TH	RT	UT	LT	TH	RT	UT	LT	TH	RT	UT	LT	TH	RT		
11:00 AM	0	0	3	1	0	1	1	2	0	2	8	1	0	3	5	1	28	0
11:15 AM	0	0	0	1	0	1	0	0	0	3	6	2	1	3	13	0	30	0
11:30 AM	0	1	0	0	0	1	4	1	0	0	7	0	0	2	8	0	24	0
11:45 AM	0	1	1	0	0	0	1	0	0	0	2	0	1	0	4	0	10	92
12:00 PM	0	0	1	0	0	0	0	2	0	0	5	0	0	1	7	1	17	81
12:15 PM	0	2	4	0	0	1	1	0	0	0	8	0	0	1	11	2	30	81
12:30 PM	0	0	4	2	0	1	1	1	0	0	10	0	0	1	5	0	25	82
12:45 PM	0	0	2	1	0	0	0	0	0	0	8	0	0	0	10	0	21	93
1:00 PM	0	0	1	0	0	1	1	0	0	0	9	1	0	0	8	0	21	97
1:15 PM	0	1	1	0	0	2	1	0	0	0	3	1	0	0	15	2	26	93
1:30 PM	0	0	1	0	0	1	0	1	1	0	4	1	0	1	14	0	24	92
1:45 PM	0	0	3	0	0	0	1	0	1	0	7	0	0	0	5	0	17	88
2:00 PM	0	0	1	2	0	1	1	1	0	2	7	1	0	1	4	1	22	89
2:15 PM	0	0	1	0	0	2	1	0	0	0	5	2	0	0	12	3	26	89
2:30 PM	0	0	0	1	0	2	1	0	1	0	5	1	0	2	5	0	18	83
2:45 PM	0	0	0	0	0	0	1	1	0	0	3	3	0	0	4	0	12	78
Count Total	0	5	23	8	0	14	15	9	3	7	97	13	2	15	130	10	351	
Pk Hr Heavy	0	1	6	2	0	4	3	2	2	2	21	3	0	2	38	3	89	
Count Summaries - Bikes																		
Interval Start	Orchard Ave				Carlos Bee Blvd				Mission Blvd				Mission Blvd				15-min Total	Rolling Hour Total
	Eastbound				Westbound				Northbound				Southbound					
	UT	LT	TH	RT	UT	LT	TH	RT	UT	LT	TH	RT	UT	LT	TH	RT		
11:00 AM	0	0	0	0	0	0	0	0	0	0	0	0	0	0	0	0	0	0
11:15 AM	0	0	0	0	0	0	0	0	0	0	0	0	0	1	0	0	1	0
11:30 AM	0	0	0	0	0	0	0	0	0	0	0	0	0	0	0	0	0	0
11:45 AM	0	0	0	0	0	0	0	0	0	0	0	0	0	0	0	0	0	1
12:00 PM	0	0	0	0	0	0	0	0	0	0	0	0	0	0	1	0	1	2
12:15 PM	0	0	0	0	0	0	0	0	0	0	0	0	0	0	0	0	0	1
12:30 PM	0	0	0	0	0	0	0	0	0	0	0	0	0	0	0	0	0	1
12:45 PM	0	0	0	0	0	0	0	0	0	0	0	0	0	0	0	0	0	1
1:00 PM	0	0	0	0	0	0	0	0	0	0	0	0	0	0	1	0	1	1
1:15 PM	0	0	0	0	0	0	0	0	0	0	0	0	0	0	0	0	0	1
1:30 PM	0	0	0	0	0	0	0	0	0	0	0	0	0	0	0	0	0	1
1:45 PM	0	0	0	0	0	0	0	0	0	0	0	0	0	0	0	0	0	1
2:00 PM	0	0	0	0	0	0	0	0	0	0	0	0	0	0	1	0	1	1
2:15 PM	0	0	0	0	0	0	0	0	0	0	0	1	0	0	0	0	1	2
2:30 PM	0	0	0	0	0	0	0	1	0	0	0	0	0	0	0	0	1	3
2:45 PM	0	0	0	0	0	0	0	0	0	0	0	0	0	0	0	0	0	3
Count Total	0	0	0	0	0	0	0	1	0	0	0	1	0	1	3	0	6	
Pk Hr Bike	0	0	0	0	0	0	0	0	0	0	0	0	0	0	1	0	1	

Mission Blvd Orchard Ave



Peak Hour

Date: 2/15/2023
 Count Period: 3:00 PM to 7:00 PM
 Peak Hour: 4:15 PM to 5:15 PM

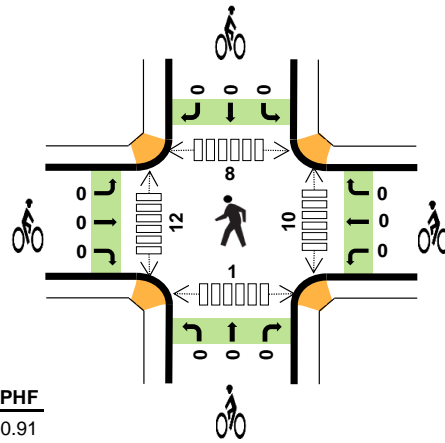
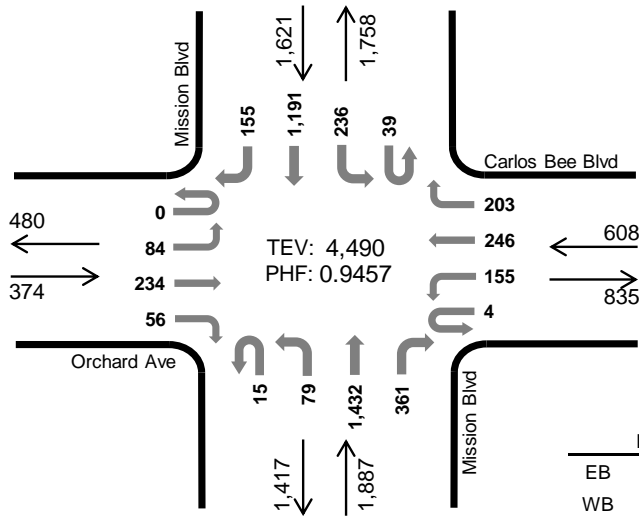

	HV%	PHF
EB	0%	0.91
WB	1%	0.96
NB	1%	0.90
SB	1%	0.92
TOTAL	1%	0.95

Peak Hour Count Summaries

Peak Hour Interval Start	Orchard Ave				Carlos Bee Blvd				Mission Blvd				Mission Blvd				15-min Total	Rolling Hour Total	
	Eastbound		Westbound		Northbound		Southbound		Northbound		Southbound								
	UT	LT	TH	RT	UT	LT	TH	RT	UT	LT	TH	RT	UT	LT	TH	RT			
4:15 PM	0	21	48	14	3	32	55	49	2	19	405	98	10	68	323	40	1,187	0	
4:30 PM	0	20	60	11	0	35	63	55	4	26	350	94	12	64	280	33	1,107	0	
4:45 PM	0	19	70	14	1	36	67	54	4	15	327	81	9	55	308	38	1,098	0	
5:00 PM	0	24	56	17	0	52	61	45	5	19	350	88	8	49	280	44	1,098	4,490	
Pk Hr	All	0	84	234	56	4	155	246	203	15	79	1,432	361	39	236	1,191	155	4,490	
	HV	0	0	0	0	0	3	4	1	0	1	9	1	0	0	15	0	34	
	HV%	-	0%	0%	0%	0%	2%	2%	0%	0%	1%	1%	0%	0%	0%	1%	0%	1%	

Note: For complete count summary (all intervals), see following pages.

** Heavy Vehicle Classifications include FHWA Classes 4-13.

** Count Summaries include heavy vehicles, but exclude bicycles in overall count.

Interval Start	Heavy Vehicle Totals					Bicycles					Pedestrians (Crossing Leg)				
	EB	WB	NB	SB	Total	EB	WB	NB	SB	Total	E	W	N	S	Total
4:15 PM	0	2	3	4	9	0	0	0	0	0	2	4	1	0	7
4:30 PM	0	5	3	6	14	0	0	0	0	0	2	2	1	0	5
4:45 PM	0	1	1	4	6	0	0	0	0	0	2	3	3	1	9
5:00 PM	0	0	4	1	5	0	0	0	0	0	4	3	3	0	10
Peak Hour	0	8	11	15	34	0	0	0	0	0	10	12	8	1	31

Count Summaries - All Vehicles

Interval Start	Orchard Ave				Carlos Bee Blvd				Mission Blvd				Mission Blvd				15-min Total	Rolling Hour Total	
	Eastbound				Westbound				Northbound				Southbound						
	UT	LT	TH	RT	UT	LT	TH	RT	UT	LT	TH	RT	UT	LT	TH	RT			
3:00 PM	0	22	54	18	0	50	58	53	6	12	236	76	4	44	231	30	894	0	
3:15 PM	0	26	45	7	0	32	64	60	7	26	281	68	10	49	255	41	971	0	
3:30 PM	0	19	43	8	1	28	71	65	6	9	359	79	8	36	260	41	1,033	0	
3:45 PM	0	17	66	9	2	36	47	53	3	23	324	95	16	50	236	29	1,006	3,904	
4:00 PM	0	30	46	19	3	31	61	47	3	20	335	82	3	44	274	38	1,036	4,046	
4:15 PM	0	21	48	14	3	32	55	49	2	19	405	98	10	68	323	40	1,187	4,262	
4:30 PM	0	20	60	11	0	35	63	55	4	26	350	94	12	64	280	33	1,107	4,336	
4:45 PM	0	19	70	14	1	36	67	54	4	15	327	81	9	55	308	38	1,098	4,428	
5:00 PM	0	24	56	17	0	52	61	45	5	19	350	88	8	49	280	44	1,098	4,490	
5:15 PM	0	20	72	15	0	40	50	49	4	17	332	90	9	53	315	38	1,104	4,407	
5:30 PM	1	20	66	25	0	37	50	44	4	26	320	102	14	61	323	40	1,133	4,433	
5:45 PM	0	19	56	7	0	30	54	49	5	22	350	98	6	51	282	41	1,070	4,405	
6:00 PM	0	18	71	19	1	50	63	63	3	9	298	66	21	48	260	24	1,014	4,321	
6:15 PM	0	18	68	9	0	33	43	64	6	20	360	76	11	53	256	29	1,046	4,263	
6:30 PM	0	16	64	13	1	34	58	50	3	15	321	77	13	43	239	28	975	4,105	
6:45 PM	1	21	71	13	0	31	30	34	2	11	287	93	9	56	243	31	933	3,968	
Count Total	2	330	956	218	12	587	895	834	67	289	5,235	1,363	163	824	4,365	565	16,705		
Pk Hr	All	0	84	234	56	4	155	246	203	15	79	1,432	361	39	236	1,191	155	4,490	
	HV	0	0	0	0	0	3	4	1	0	1	9	1	0	0	15	0	34	
	HV%	-	0%	0%	0%	0%	2%	2%	0%	0%	1%	1%	0%	0%	0%	1%	0%	1%	

Interval Start	Heavy Vehicle Totals					Bicycles					Pedestrians (Crossing Leg)				
	EB	WB	NB	SB	Total	EB	WB	NB	SB	Total	E	W	N	S	Total
3:00 PM	1	3	8	6	18	0	0	0	0	0	5	2	1	0	8
3:15 PM	0	0	10	5	15	0	0	0	0	0	5	2	2	0	9
3:30 PM	0	3	6	6	15	0	0	1	1	2	1	3	1	0	5
3:45 PM	0	2	10	5	17	0	0	0	0	0	1	8	5	0	14
4:00 PM	1	4	6	6	17	0	0	0	0	0	0	6	2	0	8
4:15 PM	0	2	3	4	9	0	0	0	0	0	2	4	1	0	7
4:30 PM	0	5	3	6	14	0	0	0	0	0	2	2	1	0	5
4:45 PM	0	1	1	4	6	0	0	0	0	0	2	3	3	1	9
5:00 PM	0	0	4	1	5	0	0	0	0	0	4	3	3	0	10
5:15 PM	1	1	2	5	9	0	0	0	0	0	1	3	2	0	6
5:30 PM	3	0	5	8	16	0	0	0	0	0	5	1	0	1	7
5:45 PM	0	0	6	3	9	0	0	0	0	0	1	3	2	0	6
6:00 PM	0	1	0	4	5	0	0	0	0	0	1	4	0	0	5
6:15 PM	1	0	3	3	7	0	0	0	0	0	1	1	0	0	2
6:30 PM	1	0	3	1	5	0	0	0	0	0	1	1	0	0	2
6:45 PM	0	0	2	3	5	0	0	0	0	0	1	0	0	0	1
Count Total	8	22	72	70	172	0	0	1	1	2	33	46	23	2	104
Peak Hour	0	8	11	15	34	0	0	0	0	0	10	12	8	1	31

Count Summaries - Heavy Vehicles																		
Interval Start	Orchard Ave				Carlos Bee Blvd				Mission Blvd				Mission Blvd				15-min Total	Rolling Hour Total
	Eastbound				Westbound				Northbound				Southbound					
	UT	LT	TH	RT	UT	LT	TH	RT	UT	LT	TH	RT	UT	LT	TH	RT		
3:00 PM	0	0	0	1	0	1	0	2	0	1	6	1	1	0	5	0	18	0
3:15 PM	0	0	0	0	0	0	0	0	0	1	7	2	0	1	2	2	15	0
3:30 PM	0	0	0	0	0	1	1	1	0	0	5	1	0	0	6	0	15	0
3:45 PM	0	0	0	0	0	0	2	0	0	1	8	1	0	0	4	1	17	65
4:00 PM	0	0	0	1	0	2	1	1	0	1	3	2	0	0	4	2	17	64
4:15 PM	0	0	0	0	0	1	1	0	0	0	3	0	0	0	4	0	9	58
4:30 PM	0	0	0	0	0	2	2	1	0	0	2	1	0	0	6	0	14	57
4:45 PM	0	0	0	0	0	0	1	0	0	0	1	0	0	0	4	0	6	46
5:00 PM	0	0	0	0	0	0	0	0	0	1	3	0	0	0	1	0	5	34
5:15 PM	0	0	1	0	0	0	0	1	0	0	2	0	0	1	4	0	9	34
5:30 PM	0	0	3	0	0	0	0	0	0	1	4	0	0	1	7	0	16	36
5:45 PM	0	0	0	0	0	0	0	0	1	1	4	0	0	0	3	0	9	39
6:00 PM	0	0	0	0	0	0	1	0	0	0	0	0	0	0	4	0	5	39
6:15 PM	0	0	0	1	0	0	0	0	0	0	3	0	0	0	3	0	7	37
6:30 PM	0	1	0	0	0	0	0	0	0	0	3	0	0	0	1	0	5	26
6:45 PM	0	0	0	0	0	0	0	0	0	0	2	0	0	0	2	1	5	22
Count Total	0	1	4	3	0	7	9	6	1	7	56	8	1	3	60	6	172	
Pk Hr Heavy	0	0	0	0	0	3	4	1	0	1	9	1	0	0	15	0	34	

Count Summaries - Bikes																		
Interval Start	Orchard Ave				Carlos Bee Blvd				Mission Blvd				Mission Blvd				15-min Total	Rolling Hour Total
	Eastbound				Westbound				Northbound				Southbound					
	UT	LT	TH	RT	UT	LT	TH	RT	UT	LT	TH	RT	UT	LT	TH	RT		
3:00 PM	0	0	0	0	0	0	0	0	0	0	0	0	0	0	0	0	0	0
3:15 PM	0	0	0	0	0	0	0	0	0	0	0	0	0	0	0	0	0	0
3:30 PM	0	0	0	0	0	0	0	0	0	0	0	1	0	0	1	0	2	0
3:45 PM	0	0	0	0	0	0	0	0	0	0	0	0	0	0	0	0	0	2
4:00 PM	0	0	0	0	0	0	0	0	0	0	0	0	0	0	0	0	0	2
4:15 PM	0	0	0	0	0	0	0	0	0	0	0	0	0	0	0	0	0	2
4:30 PM	0	0	0	0	0	0	0	0	0	0	0	0	0	0	0	0	0	0
4:45 PM	0	0	0	0	0	0	0	0	0	0	0	0	0	0	0	0	0	0
5:00 PM	0	0	0	0	0	0	0	0	0	0	0	0	0	0	0	0	0	0
5:15 PM	0	0	0	0	0	0	0	0	0	0	0	0	0	0	0	0	0	0
5:30 PM	0	0	0	0	0	0	0	0	0	0	0	0	0	0	0	0	0	0
5:45 PM	0	0	0	0	0	0	0	0	0	0	0	0	0	0	0	0	0	0
6:00 PM	0	0	0	0	0	0	0	0	0	0	0	0	0	0	0	0	0	0
6:15 PM	0	0	0	0	0	0	0	0	0	0	0	0	0	0	0	0	0	0
6:30 PM	0	0	0	0	0	0	0	0	0	0	0	0	0	0	0	0	0	0
6:45 PM	0	0	0	0	0	0	0	0	0	0	0	0	0	0	0	0	0	0
Count Total	0	0	0	0	0	0	0	0	0	0	0	1	0	0	1	0	2	
Pk Hr Bike	0	0	0	0	0	0	0	0	0	0	0	0	0	0	0	0	0	

Joyce St Orchard Ave



Date: 1/29/2025
 Count Period: 7:00 AM to 11:00 AM
 Peak Hour: 7:30 AM to 8:30 AM

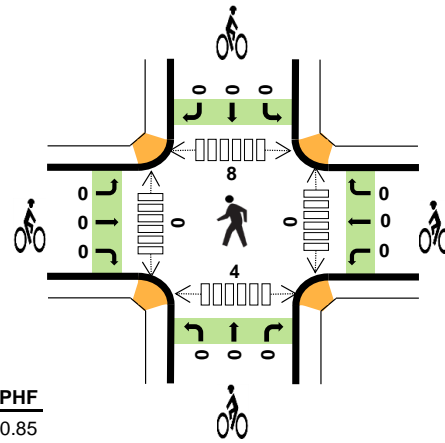
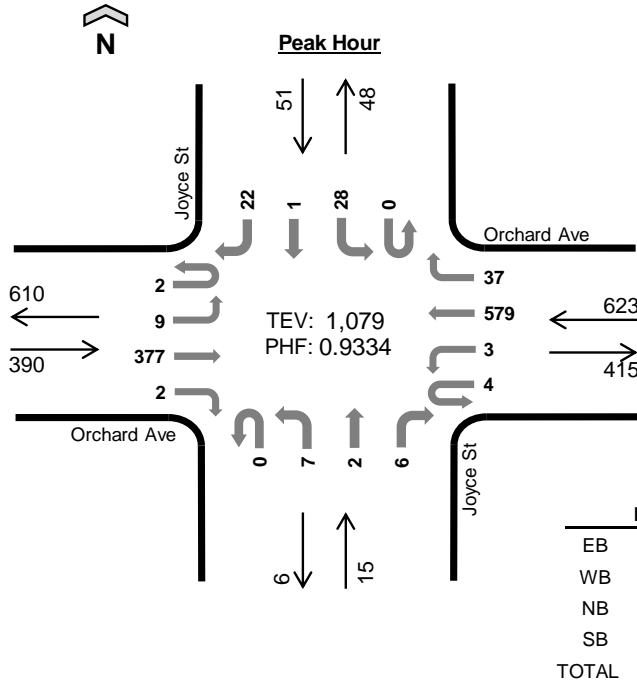

	HV%	PHF
EB	3%	0.85
WB	1%	0.88
NB	0%	0.63
SB	2%	0.71
TOTAL	2%	0.93

Peak Hour Count Summaries

Peak Hour Interval Start	Orchard Ave Eastbound				Orchard Ave Westbound				Joyce St Northbound				Joyce St Southbound				15-min Total	Rolling Hour Total	
	UT	LT	TH	RT	UT	LT	TH	RT	UT	LT	TH	RT	UT	LT	TH	RT			
7:30 AM	0	5	79	0	0	1	161	10	0	3	0	1	0	3	0	7	270	0	
7:45 AM	0	1	87	0	0	1	165	11	0	2	1	3	0	9	0	9	289	0	
8:00 AM	0	3	111	1	3	0	126	9	0	1	1	2	0	12	0	2	271	0	
8:15 AM	2	0	100	1	1	1	127	7	0	1	0	0	0	4	1	4	249	1,079	
Pk Hr	All	2	9	377	2	4	3	579	37	0	7	2	6	0	28	1	22	1,079	
	HV	2	1	9	0	0	0	5	2	0	0	0	0	0	0	0	1	20	
	HV%	100%	11%	2%	0%	0%	0%	1%	5%	-	0%	0%	0%	-	0%	0%	5%	2%	

Note: For complete count summary (all intervals), see following pages.

** Heavy Vehicle Classifications include FHWA Classes 4-13.

** Count Summaries include heavy vehicles, but exclude bicycles in overall count.

Interval Start	Heavy Vehicle Totals					Bicycles					Pedestrians (Crossing Leg)				
	EB	WB	NB	SB	Total	EB	WB	NB	SB	Total	E	W	N	S	Total
7:30 AM	4	1	0	1	6	0	0	0	0	0	0	0	2	2	4
7:45 AM	0	4	0	0	4	0	0	0	0	0	0	0	0	0	0
8:00 AM	1	1	0	0	2	0	0	0	0	0	0	0	3	1	4
8:15 AM	7	1	0	0	8	0	0	0	0	0	0	0	3	1	4
Peak Hour	12	7	0	1	20	0	0	0	0	0	0	0	8	4	12

Count Summaries - All Vehicles																			
Interval Start	Orchard Ave				Orchard Ave				Joyce St				Joyce St				15-min Total	Rolling Hour Total	
	Eastbound				Westbound				Northbound				Southbound						
	UT	LT	TH	RT	UT	LT	TH	RT	UT	LT	TH	RT	UT	LT	TH	RT			
7:00 AM	0	0	39	1	0	0	109	6	0	1	0	2	0	4	0	7	169	0	
7:15 AM	2	1	48	0	1	0	119	8	0	1	0	4	0	6	1	1	192	0	
7:30 AM	0	5	79	0	0	1	161	10	0	3	0	1	0	3	0	7	270	0	
7:45 AM	0	1	87	0	0	1	165	11	0	2	1	3	0	9	0	9	289	920	
8:00 AM	0	3	111	1	3	0	126	9	0	1	1	2	0	12	0	2	271	1,022	
8:15 AM	2	0	100	1	1	1	127	7	0	1	0	0	0	4	1	4	249	1,079	
8:30 AM	0	1	97	0	0	1	120	8	1	3	0	1	0	7	1	3	243	1,052	
8:45 AM	0	0	78	0	0	1	114	6	0	0	1	2	0	5	0	2	209	972	
9:00 AM	0	1	63	0	1	0	81	6	0	1	0	1	1	2	0	2	159	860	
9:15 AM	0	1	52	2	0	1	92	1	0	0	0	2	0	3	1	2	157	768	
9:30 AM	1	2	48	0	0	1	81	3	0	1	0	0	0	6	0	3	146	671	
9:45 AM	0	0	52	0	0	0	100	5	0	0	1	1	0	2	0	3	164	626	
10:00 AM	0	1	48	1	0	0	93	0	0	0	0	0	0	0	0	2	145	612	
10:15 AM	0	2	60	0	0	2	81	5	0	1	0	1	0	1	1	1	155	610	
10:30 AM	0	1	63	0	0	3	78	2	0	0	1	0	0	0	0	0	148	612	
10:45 AM	0	3	57	0	2	0	106	1	0	0	0	0	0	3	0	2	174	622	
Count Total	5	22	1,082	6	8	12	1,753	88	1	15	5	20	1	67	5	50	3,140		
Pk Hr	All	2	9	377	2	4	3	579	37	0	7	2	6	0	28	1	22	1,079	
	HV	2	1	9	0	0	0	5	2	0	0	0	0	0	0	0	1	20	
	HV%	100%	11%	2%	0%	0%	0%	1%	5%	-	0%	0%	0%	-	0%	0%	5%	2%	

Interval Start	Heavy Vehicle Totals					Bicycles					Pedestrians (Crossing Leg)				
	EB	WB	NB	SB	Total	EB	WB	NB	SB	Total	E	W	N	S	Total
7:00 AM	1	3	0	0	4	0	0	0	0	0	0	0	2	0	2
7:15 AM	2	2	0	0	4	0	0	0	0	0	0	0	0	2	2
7:30 AM	4	1	0	1	6	0	0	0	0	0	0	0	2	2	4
7:45 AM	0	4	0	0	4	0	0	0	0	0	0	0	0	0	0
8:00 AM	1	1	0	0	2	0	0	0	0	0	0	0	3	1	4
8:15 AM	7	1	0	0	8	0	0	0	0	0	0	0	3	1	4
8:30 AM	4	2	0	1	7	0	1	0	1	2	0	0	0	0	0
8:45 AM	2	1	0	0	3	0	0	0	0	0	0	0	1	0	1
9:00 AM	0	1	0	1	2	0	0	0	0	0	0	0	1	0	1
9:15 AM	4	1	0	0	5	0	0	0	0	0	0	0	2	3	5
9:30 AM	1	2	0	1	4	0	0	0	0	0	0	0	0	0	0
9:45 AM	1	1	0	0	2	0	0	0	0	0	0	0	1	2	3
10:00 AM	2	2	0	0	4	0	0	0	0	0	0	0	1	0	1
10:15 AM	1	2	0	1	4	0	0	0	0	0	0	0	0	0	0
10:30 AM	0	1	0	0	1	0	0	0	0	0	0	0	4	0	4
10:45 AM	3	4	0	0	7	0	0	0	0	0	0	0	0	0	0
Count Total	33	29	0	5	67	0	1	0	1	2	0	0	20	11	31
Peak Hour	12	7	0	1	20	0	0	0	0	0	0	0	8	4	12

Count Summaries - Heavy Vehicles																		
Interval Start	Orchard Ave				Orchard Ave				Joyce St				Joyce St				15-min Total	Rolling Hour Total
	Eastbound				Westbound				Northbound				Southbound					
	UT	LT	TH	RT	UT	LT	TH	RT	UT	LT	TH	RT	UT	LT	TH	RT		
7:00 AM	0	0	1	0	0	0	3	0	0	0	0	0	0	0	0	4	0	
7:15 AM	0	0	2	0	0	0	1	1	0	0	0	0	0	0	0	4	0	
7:30 AM	0	1	3	0	0	0	1	0	0	0	0	0	0	0	1	6	0	
7:45 AM	0	0	0	0	0	0	2	2	0	0	0	0	0	0	0	4	18	
8:00 AM	0	0	1	0	0	0	1	0	0	0	0	0	0	0	0	2	16	
8:15 AM	2	0	5	0	0	0	1	0	0	0	0	0	0	0	0	8	20	
8:30 AM	0	0	4	0	0	0	2	0	0	0	0	0	0	0	1	7	21	
8:45 AM	0	0	2	0	0	0	1	0	0	0	0	0	0	0	0	3	20	
9:00 AM	0	0	0	0	0	0	0	1	0	0	0	0	0	0	1	2	20	
9:15 AM	0	1	3	0	0	0	1	0	0	0	0	0	0	0	0	5	17	
9:30 AM	0	0	1	0	0	0	2	0	0	0	0	0	1	0	0	4	14	
9:45 AM	0	0	1	0	0	0	1	0	0	0	0	0	0	0	0	2	13	
10:00 AM	0	0	2	0	0	0	2	0	0	0	0	0	0	0	0	4	15	
10:15 AM	0	0	1	0	0	0	1	1	0	0	0	0	0	0	1	4	14	
10:30 AM	0	0	0	0	0	0	1	0	0	0	0	0	0	0	0	1	11	
10:45 AM	0	0	3	0	0	0	4	0	0	0	0	0	0	0	0	7	16	
Count Total	2	2	29	0	0	0	24	5	0	0	0	0	0	1	0	67		
Pk Hr Heavy	2	1	9	0	0	0	5	2	0	0	0	0	0	0	1	20		
Count Summaries - Bikes																		
Interval Start	Orchard Ave				Orchard Ave				Joyce St				Joyce St				15-min Total	Rolling Hour Total
	Eastbound				Westbound				Northbound				Southbound					
	UT	LT	TH	RT	UT	LT	TH	RT	UT	LT	TH	RT	UT	LT	TH	RT		
7:00 AM	0	0	0	0	0	0	0	0	0	0	0	0	0	0	0	0	0	
7:15 AM	0	0	0	0	0	0	0	0	0	0	0	0	0	0	0	0	0	
7:30 AM	0	0	0	0	0	0	0	0	0	0	0	0	0	0	0	0	0	
7:45 AM	0	0	0	0	0	0	0	0	0	0	0	0	0	0	0	0	0	
8:00 AM	0	0	0	0	0	0	0	0	0	0	0	0	0	0	0	0	0	
8:15 AM	0	0	0	0	0	0	0	0	0	0	0	0	0	0	0	0	0	
8:30 AM	0	0	0	0	0	0	0	1	0	0	0	0	0	1	0	2	2	
8:45 AM	0	0	0	0	0	0	0	0	0	0	0	0	0	0	0	0	2	
9:00 AM	0	0	0	0	0	0	0	0	0	0	0	0	0	0	0	0	2	
9:15 AM	0	0	0	0	0	0	0	0	0	0	0	0	0	0	0	0	2	
9:30 AM	0	0	0	0	0	0	0	0	0	0	0	0	0	0	0	0	0	
9:45 AM	0	0	0	0	0	0	0	0	0	0	0	0	0	0	0	0	0	
10:00 AM	0	0	0	0	0	0	0	0	0	0	0	0	0	0	0	0	0	
10:15 AM	0	0	0	0	0	0	0	0	0	0	0	0	0	0	0	0	0	
10:30 AM	0	0	0	0	0	0	0	0	0	0	0	0	0	0	0	0	0	
10:45 AM	0	0	0	0	0	0	0	0	0	0	0	0	0	0	0	0	0	
Count Total	0	0	0	0	0	0	0	1	0	0	0	0	0	1	0	2		
Pk Hr Bike	0	0	0	0	0	0	0	0	0	0	0	0	0	0	0	0		

Joyce St Orchard Ave



Peak Hour

Date: 1/29/2025
 Count Period: 11:00 AM to 3:00 PM
 Peak Hour: 1:00 PM to 2:00 PM

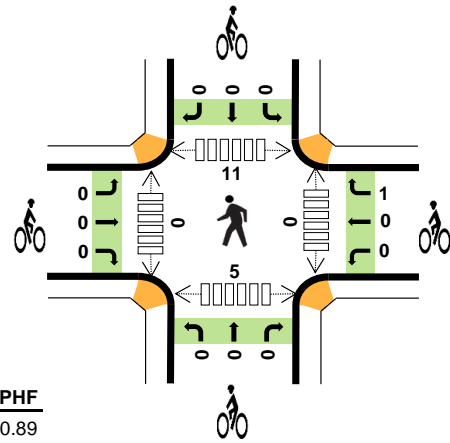
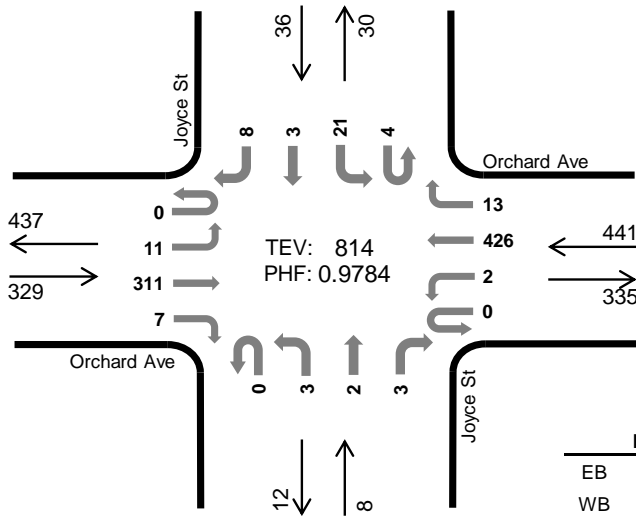

	HV%	PHF
EB	3%	0.89
WB	1%	0.91
NB	0%	0.50
SB	0%	0.82
TOTAL	2%	0.98

Peak Hour Count Summaries

Peak Hour Interval Start	Orchard Ave				Orchard Ave				Joyce St				Joyce St				15-min Total	Rolling Hour Total	
	Eastbound		Westbound		Northbound		Southbound		Northbound		Southbound								
	UT	LT	TH	RT	UT	LT	TH	RT	UT	LT	TH	RT	UT	LT	TH	RT			
1:00 PM	0	1	67	1	0	1	115	5	0	0	2	0	1	4	1	2	200	0	
1:15 PM	0	2	76	4	0	0	110	1	0	3	0	1	0	6	1	3	207	0	
1:30 PM	0	7	79	0	0	1	96	4	0	0	0	1	2	5	1	3	199	0	
1:45 PM	0	1	89	2	0	0	105	3	0	0	0	1	1	6	0	0	208	814	
Pk Hr	All	0	11	311	7	0	2	426	13	0	3	2	3	4	21	3	8	814	
	HV	0	1	9	0	0	0	6	0	0	0	0	0	0	0	0	0	16	
	HV%	-	9%	3%	0%	-	0%	1%	0%	-	0%	0%	0%	0%	0%	0%	0%	2%	

Note: For complete count summary (all intervals), see following pages.

** Heavy Vehicle Classifications include FHWA Classes 4-13.

** Count Summaries include heavy vehicles, but exclude bicycles in overall count.

Interval Start	Heavy Vehicle Totals					Bicycles					Pedestrians (Crossing Leg)				
	EB	WB	NB	SB	Total	EB	WB	NB	SB	Total	E	W	N	S	Total
1:00 PM	3	1	0	0	4	0	0	0	0	0	0	0	6	3	9
1:15 PM	1	2	0	0	3	0	0	0	0	0	0	0	3	2	5
1:30 PM	3	2	0	0	5	0	0	0	0	0	0	0	1	0	1
1:45 PM	3	1	0	0	4	0	1	0	0	1	0	0	1	0	1
Peak Hour	10	6	0	0	16	0	1	0	0	1	0	0	11	5	16

Count Summaries - All Vehicles

Interval Start	Orchard Ave				Orchard Ave				Joyce St				Joyce St				15-min Total	Rolling Hour Total	
	Eastbound				Westbound				Northbound				Southbound						
	UT	LT	TH	RT	UT	LT	TH	RT	UT	LT	TH	RT	UT	LT	TH	RT			
11:00 AM	1	0	45	0	0	0	82	3	0	0	0	1	0	1	0	1	134	0	
11:15 AM	0	2	53	1	1	1	95	3	0	2	0	3	0	2	0	5	168	0	
11:30 AM	1	1	64	1	0	1	74	3	0	1	1	1	0	0	0	1	149	0	
11:45 AM	0	3	58	0	0	0	94	1	0	1	0	1	0	3	1	2	164	615	
12:00 PM	0	2	76	2	0	0	77	6	0	1	0	2	0	6	0	5	177	658	
12:15 PM	0	4	54	0	0	1	84	5	0	0	0	1	0	8	1	6	164	654	
12:30 PM	0	5	86	0	0	2	95	5	0	0	0	0	0	7	1	1	202	707	
12:45 PM	0	0	94	2	0	1	86	4	0	1	0	0	0	0	0	2	190	733	
1:00 PM	0	1	67	1	0	1	115	5	0	0	2	0	1	4	1	2	200	756	
1:15 PM	0	2	76	4	0	0	110	1	0	3	0	1	0	6	1	3	207	799	
1:30 PM	0	7	79	0	0	1	96	4	0	0	0	1	2	5	1	3	199	796	
1:45 PM	0	1	89	2	0	0	105	3	0	0	0	1	1	6	0	0	208	814	
2:00 PM	0	4	76	0	1	0	85	4	0	0	0	2	0	3	1	1	177	791	
2:15 PM	0	5	70	1	0	0	72	6	0	0	0	2	0	10	0	3	169	753	
2:30 PM	0	0	102	1	1	0	83	4	0	1	0	2	0	3	2	2	201	755	
2:45 PM	0	4	99	4	0	0	99	5	0	0	0	1	0	5	2	6	225	772	
Count Total	2	41	1,188	19	3	8	1,452	62	0	10	3	19	4	69	11	43	2,934		
Pk Hr	All	0	11	311	7	0	2	426	13	0	3	2	3	4	21	3	8	814	
	HV	0	1	9	0	0	6	0	0	0	0	0	0	0	0	0	0	16	
	HV%	-	9%	3%	0%	-	0%	1%	0%	-	0%	0%	0%	0%	0%	0%	0%	2%	

Interval Start	Heavy Vehicle Totals					Bicycles					Pedestrians (Crossing Leg)				
	EB	WB	NB	SB	Total	EB	WB	NB	SB	Total	E	W	N	S	Total
11:00 AM	0	2	0	0	2	0	1	0	1	2	0	1	0	1	2
11:15 AM	2	2	0	1	5	0	0	0	0	0	0	0	0	3	3
11:30 AM	1	3	0	0	4	0	0	0	0	0	0	0	3	0	3
11:45 AM	1	0	0	0	1	0	0	0	0	0	0	0	1	0	1
12:00 PM	0	1	0	0	1	0	0	0	0	0	0	0	2	1	3
12:15 PM	2	0	0	0	2	0	0	0	0	0	0	0	0	1	1
12:30 PM	0	0	0	0	0	0	0	0	0	0	0	0	4	0	4
12:45 PM	0	2	0	0	2	0	0	0	0	0	0	0	1	0	1
1:00 PM	3	1	0	0	4	0	0	0	0	0	0	0	6	3	9
1:15 PM	1	2	0	0	3	0	0	0	0	0	0	0	3	2	5
1:30 PM	3	2	0	0	5	0	0	0	0	0	0	0	1	0	1
1:45 PM	3	1	0	0	4	0	1	0	0	1	0	0	1	0	1
2:00 PM	0	1	0	1	2	0	0	0	0	0	0	0	3	0	3
2:15 PM	0	3	1	1	5	0	0	0	0	0	0	0	0	0	0
2:30 PM	3	2	0	0	5	0	0	0	0	0	0	1	4	1	6
2:45 PM	0	2	0	2	4	0	1	0	0	1	0	0	3	0	3
Count Total	19	24	1	5	49	0	3	0	1	4	0	2	32	12	46
Peak Hour	10	6	0	0	16	0	1	0	0	1	0	0	11	5	16

Count Summaries - Heavy Vehicles																		
Interval Start	Orchard Ave				Orchard Ave				Joyce St				Joyce St				15-min Total	Rolling Hour Total
	Eastbound				Westbound				Northbound				Southbound					
	UT	LT	TH	RT	UT	LT	TH	RT	UT	LT	TH	RT	UT	LT	TH	RT		
11:00 AM	0	0	0	0	0	0	2	0	0	0	0	0	0	0	0	2	0	
11:15 AM	0	1	1	0	0	0	2	0	0	0	0	0	0	0	1	5	0	
11:30 AM	0	0	1	0	0	0	3	0	0	0	0	0	0	0	0	4	0	
11:45 AM	0	0	1	0	0	0	0	0	0	0	0	0	0	0	0	1	12	
12:00 PM	0	0	0	0	0	0	1	0	0	0	0	0	0	0	0	1	11	
12:15 PM	0	0	2	0	0	0	0	0	0	0	0	0	0	0	0	2	8	
12:30 PM	0	0	0	0	0	0	0	0	0	0	0	0	0	0	0	0	4	
12:45 PM	0	0	0	0	0	0	2	0	0	0	0	0	0	0	0	2	5	
1:00 PM	0	0	3	0	0	0	1	0	0	0	0	0	0	0	0	4	8	
1:15 PM	0	0	1	0	0	0	2	0	0	0	0	0	0	0	0	3	9	
1:30 PM	0	0	3	0	0	0	2	0	0	0	0	0	0	0	0	5	14	
1:45 PM	0	1	2	0	0	0	1	0	0	0	0	0	0	0	0	4	16	
2:00 PM	0	0	0	0	0	0	1	0	0	0	0	0	0	1	0	2	14	
2:15 PM	0	0	0	0	0	0	2	1	0	0	0	1	0	1	0	5	16	
2:30 PM	0	0	3	0	0	0	2	0	0	0	0	0	0	0	0	5	16	
2:45 PM	0	0	0	0	0	0	2	0	0	0	0	0	1	1	0	4	16	
Count Total	0	2	17	0	0	0	23	1	0	0	0	1	0	2	2	1	49	
Pk Hr Heavy	0	1	9	0	0	0	6	0	0	0	0	0	0	0	0	0	16	
Count Summaries - Bikes																		
Interval Start	Orchard Ave				Orchard Ave				Joyce St				Joyce St				15-min Total	Rolling Hour Total
	Eastbound				Westbound				Northbound				Southbound					
	UT	LT	TH	RT	UT	LT	TH	RT	UT	LT	TH	RT	UT	LT	TH	RT		
11:00 AM	0	0	0	0	0	0	0	1	0	0	0	0	0	1	0	0	2	0
11:15 AM	0	0	0	0	0	0	0	0	0	0	0	0	0	0	0	0	0	0
11:30 AM	0	0	0	0	0	0	0	0	0	0	0	0	0	0	0	0	0	0
11:45 AM	0	0	0	0	0	0	0	0	0	0	0	0	0	0	0	0	0	2
12:00 PM	0	0	0	0	0	0	0	0	0	0	0	0	0	0	0	0	0	0
12:15 PM	0	0	0	0	0	0	0	0	0	0	0	0	0	0	0	0	0	0
12:30 PM	0	0	0	0	0	0	0	0	0	0	0	0	0	0	0	0	0	0
12:45 PM	0	0	0	0	0	0	0	0	0	0	0	0	0	0	0	0	0	0
1:00 PM	0	0	0	0	0	0	0	0	0	0	0	0	0	0	0	0	0	0
1:15 PM	0	0	0	0	0	0	0	0	0	0	0	0	0	0	0	0	0	0
1:30 PM	0	0	0	0	0	0	0	0	0	0	0	0	0	0	0	0	0	0
1:45 PM	0	0	0	0	0	0	0	1	0	0	0	0	0	0	0	0	1	1
2:00 PM	0	0	0	0	0	0	0	0	0	0	0	0	0	0	0	0	0	1
2:15 PM	0	0	0	0	0	0	0	0	0	0	0	0	0	0	0	0	0	1
2:30 PM	0	0	0	0	0	0	0	0	0	0	0	0	0	0	0	0	0	1
2:45 PM	0	0	0	0	0	0	1	0	0	0	0	0	0	0	0	1	1	1
Count Total	0	0	0	0	0	0	1	2	0	0	0	0	0	1	0	0	4	
Pk Hr Bike	0	0	0	0	0	0	0	1	0	0	0	0	0	0	0	0	1	

Joyce St Orchard Ave



Date: 1/29/2025
 Count Period: 3:00 PM to 7:00 PM
 Peak Hour: 4:30 PM to 5:30 PM

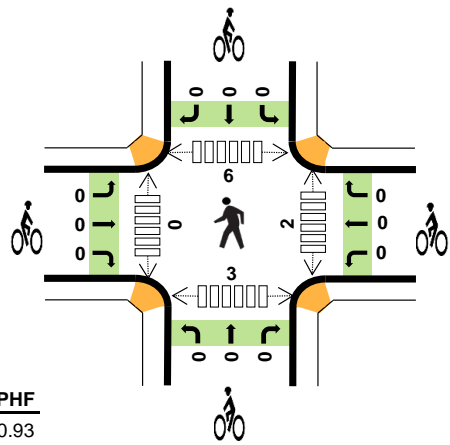
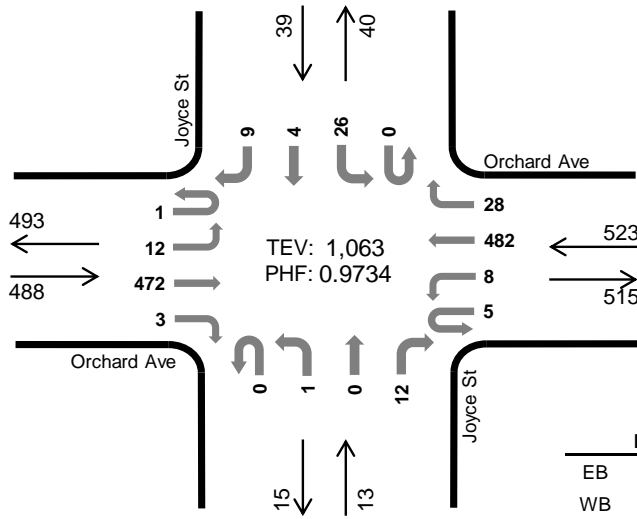

	HV%	PHF
EB	1%	0.93
WB	1%	0.94
NB	0%	0.81
SB	0%	0.75
TOTAL	1%	0.97

Peak Hour Count Summaries

Peak Hour Interval Start	Orchard Ave				Orchard Ave				Joyce St				Joyce St				15-min Total	Rolling Hour Total	
	Eastbound		Westbound		Northbound		Southbound		Northbound		Southbound								
	UT	LT	TH	RT	UT	LT	TH	RT	UT	LT	TH	RT	UT	LT	TH	RT			
4:30 PM	0	3	119	1	1	3	126	9	0	0	0	1	0	7	1	2	273	0	
4:45 PM	0	5	119	0	1	4	118	9	0	0	0	4	0	7	2	2	271	0	
5:00 PM	0	2	128	1	1	1	116	7	0	1	0	3	0	4	0	1	265	0	
5:15 PM	1	2	106	1	2	0	122	3	0	0	0	4	0	8	1	4	254	1,063	
Pk Hr	All	1	12	472	3	5	8	482	28	0	1	0	12	0	26	4	9	1,063	
	HV	0	0	4	0	0	0	5	1	0	0	0	0	0	0	0	0	10	
	HV%	0%	0%	1%	0%	0%	0%	1%	4%	-	0%	-	0%	-	0%	0%	0%	1%	

Note: For complete count summary (all intervals), see following pages.

** Heavy Vehicle Classifications include FHWA Classes 4-13.

** Count Summaries include heavy vehicles, but exclude bicycles in overall count.

Interval Start	Heavy Vehicle Totals					Bicycles				Pedestrians (Crossing Leg)					
	EB	WB	NB	SB	Total	EB	WB	NB	SB	Total	E	W	N	S	Total
4:30 PM	1	1	0	0	2	0	0	0	0	0	1	0	0	2	3
4:45 PM	0	1	0	0	1	0	0	0	0	0	0	0	2	1	3
5:00 PM	2	3	0	0	5	0	0	0	0	0	0	0	4	0	4
5:15 PM	1	1	0	0	2	0	0	0	0	0	1	0	0	0	1
Peak Hour	4	6	0	0	10	0	0	0	0	0	2	0	6	3	11

Count Summaries - All Vehicles																			
Interval Start	Orchard Ave				Orchard Ave				Joyce St				Joyce St				15-min Total	Rolling Hour Total	
	Eastbound				Westbound				Northbound				Southbound						
	UT	LT	TH	RT	UT	LT	TH	RT	UT	LT	TH	RT	UT	LT	TH	RT			
3:00 PM	0	5	97	0	2	3	106	3	0	1	1	1	0	7	0	3	229	0	
3:15 PM	0	1	103	1	2	0	122	10	0	2	0	2	0	4	1	2	250	0	
3:30 PM	0	4	73	0	0	0	99	6	0	2	0	2	0	4	0	8	198	0	
3:45 PM	0	2	110	2	1	0	96	5	0	0	0	2	0	6	0	3	227	904	
4:00 PM	0	4	108	0	1	0	109	7	0	0	1	1	0	6	0	2	239	914	
4:15 PM	0	3	114	0	0	1	97	10	0	0	1	1	0	8	1	0	236	900	
4:30 PM	0	3	119	1	1	3	126	9	0	0	0	1	0	7	1	2	273	975	
4:45 PM	0	5	119	0	1	4	118	9	0	0	0	4	0	7	2	2	271	1,019	
5:00 PM	0	2	128	1	1	1	116	7	0	1	0	3	0	4	0	1	265	1,045	
5:15 PM	1	2	106	1	2	0	122	3	0	0	0	4	0	8	1	4	254	1,063	
5:30 PM	0	6	100	0	0	3	118	9	0	2	2	2	1	8	0	1	252	1,042	
5:45 PM	1	3	101	0	1	2	94	3	0	2	0	2	0	8	0	1	218	989	
6:00 PM	2	3	101	0	0	3	101	9	0	0	1	1	0	6	0	4	231	955	
6:15 PM	0	2	107	3	0	0	111	4	0	0	0	0	0	5	2	2	236	937	
6:30 PM	0	3	97	0	0	1	73	10	0	0	0	1	0	7	0	5	197	882	
6:45 PM	1	4	86	0	0	1	68	2	0	0	0	1	0	2	0	5	170	834	
Count Total	5	52	1,669	9	12	22	1,676	106	0	10	6	28	1	97	8	45	3,746		
Pk Hr	All	1	12	472	3	5	8	482	28	0	1	0	12	0	26	4	9	1,063	
	HV	0	0	4	0	0	0	5	1	0	0	0	0	0	0	0	0	10	
	HV%	0%	0%	1%	0%	0%	0%	1%	4%	-	0%	-	0%	-	0%	0%	0%	1%	

Interval Start	Heavy Vehicle Totals					Bicycles					Pedestrians (Crossing Leg)				
	EB	WB	NB	SB	Total	EB	WB	NB	SB	Total	E	W	N	S	Total
3:00 PM	4	1	0	2	7	0	0	0	0	0	0	0	1	2	3
3:15 PM	3	3	0	1	7	0	0	0	0	0	2	0	1	0	3
3:30 PM	1	0	0	0	1	0	0	0	0	0	0	0	2	0	2
3:45 PM	0	1	0	1	2	0	0	0	1	1	0	0	1	0	1
4:00 PM	1	1	0	0	2	0	0	0	0	0	0	0	2	2	4
4:15 PM	0	2	0	0	2	0	0	0	0	0	0	0	1	3	4
4:30 PM	1	1	0	0	2	0	0	0	0	0	1	0	0	2	3
4:45 PM	0	1	0	0	1	0	0	0	0	0	0	0	2	1	3
5:00 PM	2	3	0	0	5	0	0	0	0	0	0	0	4	0	4
5:15 PM	1	1	0	0	2	0	0	0	0	0	1	0	0	0	1
5:30 PM	0	3	0	0	3	0	0	0	1	1	0	0	1	4	5
5:45 PM	0	0	0	0	0	0	0	0	0	0	0	0	2	1	3
6:00 PM	0	2	0	0	2	0	0	0	0	0	0	1	1	1	3
6:15 PM	0	0	0	0	0	0	0	0	0	0	0	1	0	2	3
6:30 PM	1	0	0	0	1	0	0	0	0	0	0	0	1	0	1
6:45 PM	0	0	0	0	0	0	0	0	0	0	0	0	0	0	0
Count Total	14	19	0	4	37	0	0	0	2	2	4	2	19	18	43
Peak Hour	4	6	0	0	10	0	0	0	0	0	2	0	6	3	11

Count Summaries - Heavy Vehicles																		
Interval Start	Orchard Ave				Orchard Ave				Joyce St				Joyce St				15-min Total	Rolling Hour Total
	Eastbound				Westbound				Northbound				Southbound					
	UT	LT	TH	RT	UT	LT	TH	RT	UT	LT	TH	RT	UT	LT	TH	RT		
3:00 PM	0	0	4	0	0	0	1	0	0	0	0	0	0	1	0	1	7	0
3:15 PM	0	0	3	0	0	0	2	1	0	0	0	0	0	0	0	1	7	0
3:30 PM	0	0	1	0	0	0	0	0	0	0	0	0	0	0	0	0	1	0
3:45 PM	0	0	0	0	0	0	1	0	0	0	0	0	0	1	0	0	2	17
4:00 PM	0	0	1	0	0	0	1	0	0	0	0	0	0	0	0	0	2	12
4:15 PM	0	0	0	0	0	0	2	0	0	0	0	0	0	0	0	0	2	7
4:30 PM	0	0	1	0	0	0	1	0	0	0	0	0	0	0	0	0	2	8
4:45 PM	0	0	0	0	0	0	1	0	0	0	0	0	0	0	0	0	1	7
5:00 PM	0	0	2	0	0	0	2	1	0	0	0	0	0	0	0	0	5	10
5:15 PM	0	0	1	0	0	0	1	0	0	0	0	0	0	0	0	0	2	10
5:30 PM	0	0	0	0	0	0	3	0	0	0	0	0	0	0	0	0	3	11
5:45 PM	0	0	0	0	0	0	0	0	0	0	0	0	0	0	0	0	0	10
6:00 PM	0	0	0	0	0	0	1	1	0	0	0	0	0	0	0	0	2	7
6:15 PM	0	0	0	0	0	0	0	0	0	0	0	0	0	0	0	0	0	5
6:30 PM	0	0	1	0	0	0	0	0	0	0	0	0	0	0	0	0	1	3
6:45 PM	0	0	0	0	0	0	0	0	0	0	0	0	0	0	0	0	0	3
Count Total	0	0	14	0	0	0	16	3	0	0	0	0	0	2	0	2	37	
Pk Hr Heavy	0	0	4	0	0	0	5	1	0	0	0	0	0	0	0	0	10	
Count Summaries - Bikes																		
Interval Start	Orchard Ave				Orchard Ave				Joyce St				Joyce St				15-min Total	Rolling Hour Total
	Eastbound				Westbound				Northbound				Southbound					
	UT	LT	TH	RT	UT	LT	TH	RT	UT	LT	TH	RT	UT	LT	TH	RT		
3:00 PM	0	0	0	0	0	0	0	0	0	0	0	0	0	0	0	0	0	0
3:15 PM	0	0	0	0	0	0	0	0	0	0	0	0	0	0	0	0	0	0
3:30 PM	0	0	0	0	0	0	0	0	0	0	0	0	0	0	0	0	0	0
3:45 PM	0	0	0	0	0	0	0	0	0	0	0	0	0	0	1	0	1	1
4:00 PM	0	0	0	0	0	0	0	0	0	0	0	0	0	0	0	0	0	1
4:15 PM	0	0	0	0	0	0	0	0	0	0	0	0	0	0	0	0	0	1
4:30 PM	0	0	0	0	0	0	0	0	0	0	0	0	0	0	0	0	0	1
4:45 PM	0	0	0	0	0	0	0	0	0	0	0	0	0	0	0	0	0	0
5:00 PM	0	0	0	0	0	0	0	0	0	0	0	0	0	0	0	0	0	0
5:15 PM	0	0	0	0	0	0	0	0	0	0	0	0	0	0	0	0	0	0
5:30 PM	0	0	0	0	0	0	0	0	0	0	0	0	0	1	0	0	1	1
5:45 PM	0	0	0	0	0	0	0	0	0	0	0	0	0	0	0	0	0	1
6:00 PM	0	0	0	0	0	0	0	0	0	0	0	0	0	0	0	0	0	1
6:15 PM	0	0	0	0	0	0	0	0	0	0	0	0	0	0	0	0	0	1
6:30 PM	0	0	0	0	0	0	0	0	0	0	0	0	0	0	0	0	0	0
6:45 PM	0	0	0	0	0	0	0	0	0	0	0	0	0	0	0	0	0	0
Count Total	0	0	0	0	0	0	0	0	0	0	0	0	0	1	1	0	2	
Pk Hr Bike	0	0	0	0	0	0	0	0	0	0	0	0	0	0	0	0	0	

Mission Blvd Orchard Ave



Peak Hour

Date: 1/29/2025
Count Period: 7:00 AM to 11:00 AM
Peak Hour: 7:30 AM to 8:30 AM

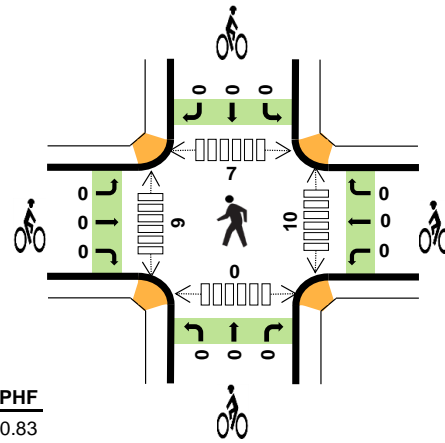
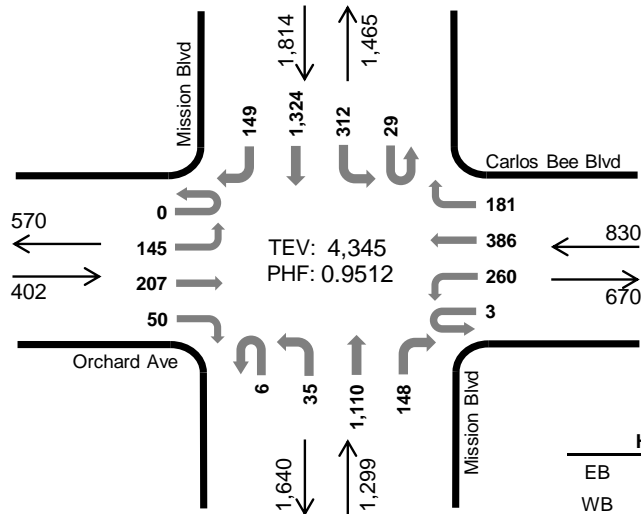

	HV%	PHF
EB	1%	0.83
WB	1%	0.92
NB	2%	0.87
SB	3%	0.91
TOTAL	2%	0.95

Peak Hour Count Summaries

Peak Hour Interval Start	Orchard Ave				Carlos Bee Blvd				Mission Blvd				Mission Blvd				15-min Total	Rolling Hour Total	
	Eastbound		Westbound		Northbound		Southbound		Northbound		Southbound								
	UT	LT	TH	RT	UT	LT	TH	RT	UT	LT	TH	RT	UT	LT	TH	RT			
7:30 AM	0	34	36	12	0	62	104	39	2	6	277	24	4	69	372	55	1,096	0	
7:45 AM	0	30	59	13	0	59	94	50	3	7	307	55	7	91	321	46	1,142	0	
8:00 AM	0	46	61	14	0	61	95	40	1	6	285	26	1	92	314	23	1,065	0	
8:15 AM	0	35	51	11	3	78	93	52	0	16	241	43	17	60	317	25	1,042	4,345	
Pk Hr	All	0	145	207	50	3	260	386	181	6	35	1,110	148	29	312	1,324	149	4,345	
	HV	0	1	3	1	0	1	3	4	0	1	23	2	1	2	44	4	90	
	HV%	-	1%	1%	2%	0%	0%	1%	2%	0%	3%	2%	1%	3%	1%	3%	3%	2%	

Note: For complete count summary (all intervals), see following pages.

** Heavy Vehicle Classifications include FHWA Classes 4-13.

** Count Summaries include heavy vehicles, but exclude bicycles in overall count.

Interval Start	Heavy Vehicle Totals					Bicycles				Pedestrians (Crossing Leg)					
	EB	WB	NB	SB	Total	EB	WB	NB	SB	Total	E	W	N	S	Total
7:30 AM	2	2	9	10	23	0	0	0	0	0	3	5	3	0	11
7:45 AM	0	3	4	22	29	0	0	0	0	0	1	2	0	0	3
8:00 AM	2	2	8	3	15	0	0	0	0	0	4	2	4	0	10
8:15 AM	1	1	5	16	23	0	0	0	0	0	2	0	0	0	2
Peak Hour	5	8	26	51	90	0	0	0	0	0	10	9	7	0	26

Count Summaries - All Vehicles																			
Interval Start	Orchard Ave				Carlos Bee Blvd				Mission Blvd				Mission Blvd				15-min Total	Rolling Hour Total	
	Eastbound				Westbound				Northbound				Southbound						
	UT	LT	TH	RT	UT	LT	TH	RT	UT	LT	TH	RT	UT	LT	TH	RT			
7:00 AM	0	22	11	9	0	83	59	38	0	8	171	15	7	16	463	34	936	0	
7:15 AM	0	39	21	15	0	68	78	50	1	7	214	14	8	29	391	40	975	0	
7:30 AM	0	34	36	12	0	62	104	39	2	6	277	24	4	69	372	55	1,096	0	
7:45 AM	0	30	59	13	0	59	94	50	3	7	307	55	7	91	321	46	1,142	4,149	
8:00 AM	0	46	61	14	0	61	95	40	1	6	285	26	1	92	314	23	1,065	4,278	
8:15 AM	0	35	51	11	3	78	93	52	0	16	241	43	17	60	317	25	1,042	4,345	
8:30 AM	0	41	45	13	4	83	95	76	3	10	184	22	24	64	291	31	986	4,235	
8:45 AM	0	29	41	12	1	42	80	52	0	10	205	24	9	105	269	26	905	3,998	
9:00 AM	0	18	39	17	0	41	63	45	2	7	165	21	4	118	235	19	794	3,727	
9:15 AM	0	13	32	6	0	35	73	46	3	7	166	15	11	141	241	15	804	3,489	
9:30 AM	0	19	29	10	0	36	57	40	4	3	211	23	5	86	203	19	745	3,248	
9:45 AM	0	16	33	10	0	33	72	46	5	14	137	15	11	80	201	25	698	3,041	
10:00 AM	0	15	27	11	1	40	63	38	2	7	156	16	3	37	196	21	633	2,880	
10:15 AM	0	15	30	13	1	24	58	37	2	14	161	23	6	69	185	18	656	2,732	
10:30 AM	0	15	36	15	0	43	59	49	3	7	175	22	5	72	193	25	719	2,706	
10:45 AM	0	13	28	13	0	30	62	81	7	16	160	26	9	109	215	24	793	2,801	
Count Total	0	400	579	194	10	818	1,205	779	38	145	3,215	384	131	1,238	4,407	446	13,989		
Pk Hr	All	0	145	207	50	3	260	386	181	6	35	1,110	148	29	312	1,324	149	4,345	
	HV	0	1	3	1	0	1	3	4	0	1	23	2	1	2	44	4	90	
	HV%	-	1%	1%	2%	0%	0%	1%	2%	0%	3%	2%	1%	3%	1%	3%	3%	2%	

Interval Start	Heavy Vehicle Totals					Bicycles					Pedestrians (Crossing Leg)				
	EB	WB	NB	SB	Total	EB	WB	NB	SB	Total	E	W	N	S	Total
7:00 AM	0	0	5	17	22	0	0	0	0	0	3	1	0	0	4
7:15 AM	1	1	4	18	24	0	0	0	0	0	0	1	0	0	1
7:30 AM	2	2	9	10	23	0	0	0	0	0	3	5	3	0	11
7:45 AM	0	3	4	22	29	0	0	0	0	0	1	2	0	0	3
8:00 AM	2	2	8	3	15	0	0	0	0	0	4	2	4	0	10
8:15 AM	1	1	5	16	23	0	0	0	0	0	2	0	0	0	2
8:30 AM	4	3	4	13	24	0	0	0	0	0	3	4	6	0	13
8:45 AM	0	1	4	10	15	0	0	0	0	0	2	2	0	0	4
9:00 AM	0	3	12	9	24	0	0	0	0	0	1	0	1	0	2
9:15 AM	2	2	5	9	18	0	0	0	0	0	1	5	2	1	9
9:30 AM	4	1	6	11	22	0	0	0	0	0	0	2	2	0	4
9:45 AM	3	1	5	6	15	0	0	0	0	0	2	3	2	0	7
10:00 AM	1	1	7	9	18	0	0	0	0	0	1	3	0	0	4
10:15 AM	1	2	7	10	20	0	0	0	0	0	0	4	3	0	7
10:30 AM	1	2	4	7	14	0	0	0	0	0	1	0	0	0	1
10:45 AM	0	1	5	9	15	0	0	0	0	0	3	4	4	0	11
Count Total	22	26	94	179	321	0	0	0	0	0	27	38	27	1	93
Peak Hour	5	8	26	51	90	0	0	0	0	0	10	9	7	0	26

Count Summaries - Heavy Vehicles																		
Interval Start	Orchard Ave				Carlos Bee Blvd				Mission Blvd				Mission Blvd				15-min Total	Rolling Hour Total
	Eastbound				Westbound				Northbound				Southbound					
	UT	LT	TH	RT	UT	LT	TH	RT	UT	LT	TH	RT	UT	LT	TH	RT		
7:00 AM	0	0	0	0	0	0	0	0	0	0	4	1	0	1	16	0	22	0
7:15 AM	0	1	0	0	0	0	1	0	0	0	3	1	1	1	13	3	24	0
7:30 AM	0	0	2	0	0	0	1	1	0	1	7	1	0	1	9	0	23	0
7:45 AM	0	0	0	0	0	1	0	2	0	0	3	1	1	1	17	3	29	98
8:00 AM	0	1	1	0	0	0	1	1	0	0	8	0	0	0	3	0	15	91
8:15 AM	0	0	0	1	0	0	1	0	0	0	5	0	0	0	15	1	23	90
8:30 AM	0	1	1	2	0	1	2	0	0	0	4	0	0	0	12	1	24	91
8:45 AM	0	0	0	0	0	0	1	0	0	0	4	0	0	2	8	0	15	77
9:00 AM	0	0	0	0	0	1	0	2	0	0	11	1	0	0	8	1	24	86
9:15 AM	0	0	1	1	0	0	1	1	0	0	5	0	0	1	8	0	18	81
9:30 AM	0	3	0	1	0	1	0	0	0	1	4	1	0	2	6	3	22	79
9:45 AM	0	0	2	1	0	0	1	0	0	0	5	0	0	0	6	0	15	79
10:00 AM	0	0	0	1	0	0	1	0	0	1	6	0	0	0	8	1	18	73
10:15 AM	0	0	0	1	0	1	0	1	0	2	5	0	0	1	8	1	20	75
10:30 AM	0	1	0	0	0	1	1	0	0	0	3	1	0	0	7	0	14	67
10:45 AM	0	0	0	0	0	1	0	0	1	0	3	1	1	0	6	2	15	67
Count Total	0	7	7	8	0	7	11	8	1	5	80	8	3	10	150	16	321	
Pk Hr Heavy	0	1	3	1	0	1	3	4	0	1	23	2	1	2	44	4	90	
Count Summaries - Bikes																		
Interval Start	Orchard Ave				Carlos Bee Blvd				Mission Blvd				Mission Blvd				15-min Total	Rolling Hour Total
	Eastbound				Westbound				Northbound				Southbound					
	UT	LT	TH	RT	UT	LT	TH	RT	UT	LT	TH	RT	UT	LT	TH	RT		
7:00 AM	0	0	0	0	0	0	0	0	0	0	0	0	0	0	0	0	0	0
7:15 AM	0	0	0	0	0	0	0	0	0	0	0	0	0	0	0	0	0	0
7:30 AM	0	0	0	0	0	0	0	0	0	0	0	0	0	0	0	0	0	0
7:45 AM	0	0	0	0	0	0	0	0	0	0	0	0	0	0	0	0	0	0
8:00 AM	0	0	0	0	0	0	0	0	0	0	0	0	0	0	0	0	0	0
8:15 AM	0	0	0	0	0	0	0	0	0	0	0	0	0	0	0	0	0	0
8:30 AM	0	0	0	0	0	0	0	0	0	0	0	0	0	0	0	0	0	0
8:45 AM	0	0	0	0	0	0	0	0	0	0	0	0	0	0	0	0	0	0
9:00 AM	0	0	0	0	0	0	0	0	0	0	0	0	0	0	0	0	0	0
9:15 AM	0	0	0	0	0	0	0	0	0	0	0	0	0	0	0	0	0	0
9:30 AM	0	0	0	0	0	0	0	0	0	0	0	0	0	0	0	0	0	0
9:45 AM	0	0	0	0	0	0	0	0	0	0	0	0	0	0	0	0	0	0
10:00 AM	0	0	0	0	0	0	0	0	0	0	0	0	0	0	0	0	0	0
10:15 AM	0	0	0	0	0	0	0	0	0	0	0	0	0	0	0	0	0	0
10:30 AM	0	0	0	0	0	0	0	0	0	0	0	0	0	0	0	0	0	0
10:45 AM	0	0	0	0	0	0	0	0	0	0	0	0	0	0	0	0	0	0
Count Total	0	0	0	0	0	0	0	0	0	0	0	0	0	0	0	0	0	
Pk Hr Bike	0	0	0	0	0	0	0	0	0	0	0	0	0	0	0	0	0	

Mission Blvd Orchard Ave



Peak Hour

Date: 1/29/2025
 Count Period: 11:00 AM to 3:00 PM
 Peak Hour: 1:15 PM to 2:15 PM

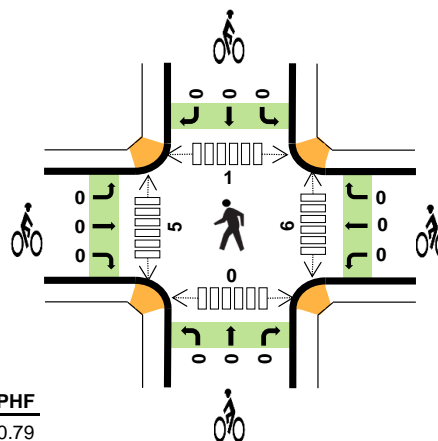
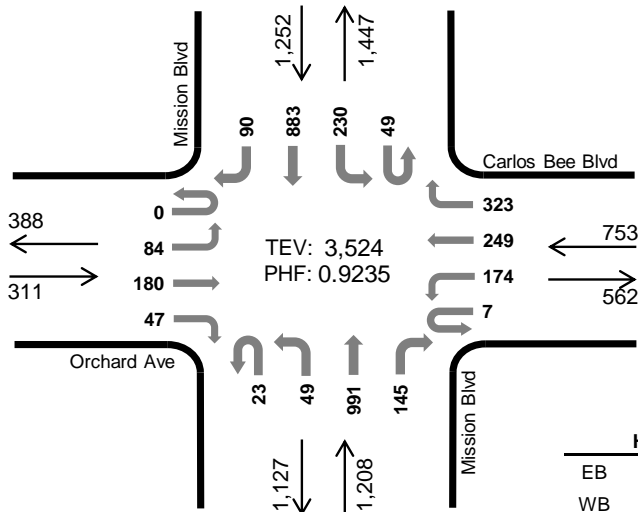

	HV%	PHF
EB	3%	0.79
WB	2%	0.84
NB	3%	0.89
SB	3%	0.95
TOTAL	3%	0.92

Peak Hour Count Summaries

Peak Hour Interval Start	Orchard Ave				Carlos Bee Blvd				Mission Blvd				Mission Blvd				15-min Total	Rolling Hour Total	
	Eastbound		Westbound		Northbound		Southbound		Northbound		Southbound								
	UT	LT	TH	RT	UT	LT	TH	RT	UT	LT	TH	RT	UT	LT	TH	RT			
1:15 PM	0	14	36	16	3	55	74	76	5	12	236	33	12	52	238	12	874	0	
1:30 PM	0	17	45	10	1	41	60	62	6	12	226	36	8	76	213	31	844	0	
1:45 PM	0	34	54	10	1	37	66	119	5	13	246	38	17	66	226	22	954	0	
2:00 PM	0	19	45	11	2	41	49	66	7	12	283	38	12	36	206	25	852	3,524	
Pk Hr	All	0	84	180	47	7	174	249	323	23	49	991	145	49	230	883	90	3,524	
	HV	0	2	6	1	0	5	6	4	1	3	28	6	0	5	28	3	98	
	HV%	-	2%	3%	2%	0%	3%	2%	1%	4%	6%	3%	4%	0%	2%	3%	3%	3%	

Note: For complete count summary (all intervals), see following pages.

** Heavy Vehicle Classifications include FHWA Classes 4-13.

** Count Summaries include heavy vehicles, but exclude bicycles in overall count.

Interval Start	Heavy Vehicle Totals					Bicycles				Pedestrians (Crossing Leg)					
	EB	WB	NB	SB	Total	EB	WB	NB	SB	Total	E	W	N	S	Total
1:15 PM	1	6	10	13	30	0	0	0	0	0	2	1	0	0	3
1:30 PM	3	4	8	6	21	0	0	0	0	0	2	0	0	0	2
1:45 PM	4	3	11	10	28	0	0	0	0	0	1	3	0	0	4
2:00 PM	1	2	9	7	19	0	0	0	0	0	1	1	1	0	3
Peak Hour	9	15	38	36	98	0	0	0	0	0	6	5	1	0	12

Count Summaries - All Vehicles

Interval Start	Orchard Ave				Carlos Bee Blvd				Mission Blvd				Mission Blvd				15-min Total	Rolling Hour Total
	Eastbound				Westbound				Northbound				Southbound					
	UT	LT	TH	RT	UT	LT	TH	RT	UT	LT	TH	RT	UT	LT	TH	RT		
11:00 AM	0	14	29	14	0	38	66	62	6	3	154	32	10	48	160	18	654	0
11:15 AM	0	14	28	10	0	25	48	41	2	16	195	33	9	37	189	26	673	0
11:30 AM	0	15	36	9	0	37	59	50	0	8	162	23	9	44	164	21	637	0
11:45 AM	0	18	34	8	1	29	55	56	3	9	192	31	8	55	183	21	703	2,667
12:00 PM	0	16	43	10	0	33	54	72	4	4	201	33	15	46	180	23	734	2,747
12:15 PM	0	16	45	10	0	35	54	96	3	11	199	32	19	55	184	24	783	2,857
12:30 PM	1	13	50	11	0	47	55	63	5	9	217	42	10	44	170	31	768	2,988
12:45 PM	0	22	62	10	1	39	49	39	5	11	209	39	20	55	191	21	773	3,058
1:00 PM	0	24	30	14	3	48	81	66	2	11	225	44	13	39	183	29	812	3,136
1:15 PM	0	14	36	16	3	55	74	76	5	12	236	33	12	52	238	12	874	3,227
1:30 PM	0	17	45	10	1	41	60	62	6	12	226	36	8	76	213	31	844	3,303
1:45 PM	0	34	54	10	1	37	66	119	5	13	246	38	17	66	226	22	954	3,484
2:00 PM	0	19	45	11	2	41	49	66	7	12	283	38	12	36	206	25	852	3,524
2:15 PM	0	22	44	5	0	35	40	51	4	8	320	48	15	28	216	27	863	3,513
2:30 PM	0	24	44	17	1	24	44	50	5	17	232	55	7	36	232	24	812	3,481
2:45 PM	0	33	47	19	1	42	57	42	4	16	329	51	5	37	229	35	947	3,474
Count Total	1	315	672	184	14	606	911	1,011	66	172	3,626	608	189	754	3,164	390	12,683	
Pk Hr All	0	84	180	47	7	174	249	323	23	49	991	145	49	230	883	90	3,524	
Pk Hr HV	0	2	6	1	0	5	6	4	1	3	28	6	0	5	28	3	98	
Pk Hr HV%	-	2%	3%	2%	0%	3%	2%	1%	4%	6%	3%	4%	0%	2%	3%	3%	3%	

Interval Start	Heavy Vehicle Totals					Bicycles					Pedestrians (Crossing Leg)				
	EB	WB	NB	SB	Total	EB	WB	NB	SB	Total	E	W	N	S	Total
11:00 AM	2	3	3	6	14	0	0	0	0	0	0	1	1	0	2
11:15 AM	3	1	11	7	22	0	0	0	0	0	0	2	0	0	2
11:30 AM	2	2	9	5	18	0	0	0	0	0	1	2	0	0	3
11:45 AM	1	0	9	4	14	0	0	0	0	0	1	0	1	0	2
12:00 PM	0	1	6	7	14	1	0	0	0	1	0	2	2	0	4
12:15 PM	1	0	9	7	17	0	0	0	0	0	0	1	1	0	2
12:30 PM	2	1	7	7	17	0	0	0	1	1	1	4	4	0	9
12:45 PM	2	2	5	7	16	0	0	0	0	0	1	5	0	0	6
1:00 PM	6	1	5	14	26	0	0	0	0	0	4	3	3	0	10
1:15 PM	1	6	10	13	30	0	0	0	0	0	2	1	0	0	3
1:30 PM	3	4	8	6	21	0	0	0	0	0	2	0	0	0	2
1:45 PM	4	3	11	10	28	0	0	0	0	0	1	3	0	0	4
2:00 PM	1	2	9	7	19	0	0	0	0	0	1	1	1	0	3
2:15 PM	2	2	15	9	28	0	0	0	0	0	1	3	0	0	4
2:30 PM	3	4	13	4	24	0	0	0	0	0	1	0	0	0	1
2:45 PM	0	4	7	4	15	0	0	0	0	0	0	6	1	0	7
Count Total	33	36	137	117	323	1	0	0	1	2	16	34	14	0	64
Peak Hour	9	15	38	36	98	0	0	0	0	0	6	5	1	0	12

Count Summaries - Heavy Vehicles																		
Interval Start	Orchard Ave				Carlos Bee Blvd				Mission Blvd				Mission Blvd				15-min Total	Rolling Hour Total
	Eastbound				Westbound				Northbound				Southbound					
	UT	LT	TH	RT	UT	LT	TH	RT	UT	LT	TH	RT	UT	LT	TH	RT		
11:00 AM	0	0	1	1	0	0	0	3	0	0	3	0	0	0	5	1	14	0
11:15 AM	0	1	2	0	0	0	1	0	0	1	8	2	0	0	7	0	22	0
11:30 AM	0	1	1	0	0	2	0	0	0	0	9	0	0	0	3	2	18	0
11:45 AM	0	0	1	0	0	0	0	0	0	0	4	5	0	1	3	0	14	68
12:00 PM	0	0	0	0	0	0	0	1	0	0	5	1	0	2	5	0	14	68
12:15 PM	0	0	1	0	0	0	0	0	1	0	4	4	0	1	5	1	17	63
12:30 PM	0	0	2	0	0	1	0	0	1	0	4	2	0	2	4	1	17	62
12:45 PM	0	0	2	0	0	0	2	0	0	0	3	2	1	0	5	1	16	64
1:00 PM	0	1	4	1	0	1	0	0	0	1	4	0	0	1	10	3	26	76
1:15 PM	0	0	1	0	0	1	3	2	0	0	9	1	0	1	12	0	30	89
1:30 PM	0	1	2	0	0	2	1	1	0	2	4	2	0	1	3	2	21	93
1:45 PM	0	0	3	1	0	1	1	1	0	1	8	2	0	2	8	0	28	105
2:00 PM	0	1	0	0	0	1	1	0	1	0	7	1	0	1	5	1	19	98
2:15 PM	0	1	1	0	0	0	2	0	0	1	11	3	0	1	7	1	28	96
2:30 PM	0	0	3	0	0	2	2	0	0	0	9	4	0	0	4	0	24	99
2:45 PM	0	0	0	0	0	0	3	1	0	1	5	1	0	1	3	0	15	86
Count Total	0	6	24	3	0	11	16	9	3	7	97	30	1	14	89	13	323	
Pk Hr Heavy	0	2	6	1	0	5	6	4	1	3	28	6	0	5	28	3	98	
Count Summaries - Bikes																		
Interval Start	Orchard Ave				Carlos Bee Blvd				Mission Blvd				Mission Blvd				15-min Total	Rolling Hour Total
	Eastbound				Westbound				Northbound				Southbound					
	UT	LT	TH	RT	UT	LT	TH	RT	UT	LT	TH	RT	UT	LT	TH	RT		
11:00 AM	0	0	0	0	0	0	0	0	0	0	0	0	0	0	0	0	0	0
11:15 AM	0	0	0	0	0	0	0	0	0	0	0	0	0	0	0	0	0	0
11:30 AM	0	0	0	0	0	0	0	0	0	0	0	0	0	0	0	0	0	0
11:45 AM	0	0	0	0	0	0	0	0	0	0	0	0	0	0	0	0	0	0
12:00 PM	0	0	1	0	0	0	0	0	0	0	0	0	0	0	0	0	1	1
12:15 PM	0	0	0	0	0	0	0	0	0	0	0	0	0	0	0	0	0	1
12:30 PM	0	0	0	0	0	0	0	0	0	0	0	0	0	0	1	0	1	2
12:45 PM	0	0	0	0	0	0	0	0	0	0	0	0	0	0	0	0	0	2
1:00 PM	0	0	0	0	0	0	0	0	0	0	0	0	0	0	0	0	0	1
1:15 PM	0	0	0	0	0	0	0	0	0	0	0	0	0	0	0	0	0	1
1:30 PM	0	0	0	0	0	0	0	0	0	0	0	0	0	0	0	0	0	0
1:45 PM	0	0	0	0	0	0	0	0	0	0	0	0	0	0	0	0	0	0
2:00 PM	0	0	0	0	0	0	0	0	0	0	0	0	0	0	0	0	0	0
2:15 PM	0	0	0	0	0	0	0	0	0	0	0	0	0	0	0	0	0	0
2:30 PM	0	0	0	0	0	0	0	0	0	0	0	0	0	0	0	0	0	0
2:45 PM	0	0	0	0	0	0	0	0	0	0	0	0	0	0	0	0	0	0
Count Total	0	0	1	0	0	0	0	0	0	0	0	0	0	0	1	0	2	
Pk Hr Bike	0	0	0	0	0	0	0	0	0	0	0	0	0	0	0	0	0	

Mission Blvd Orchard Ave



Peak Hour

Date: 1/29/2025
 Count Period: 3:00 PM to 7:00 PM
 Peak Hour: 4:30 PM to 5:30 PM

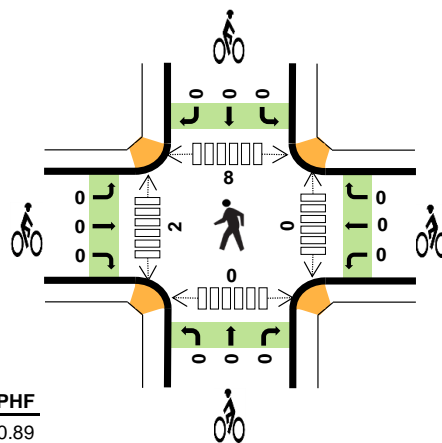
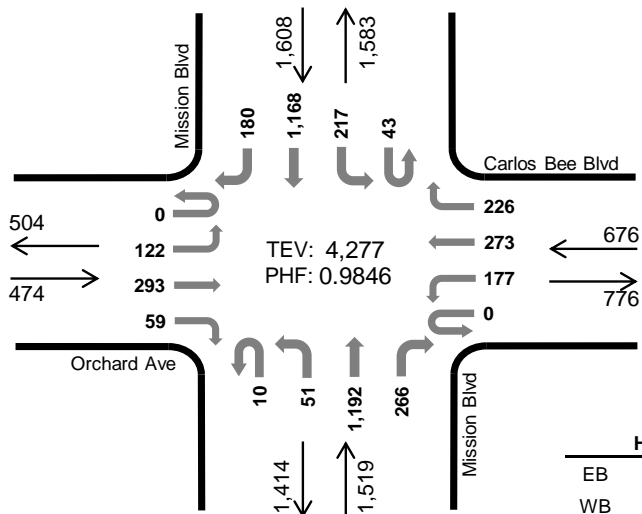

	HV%	PHF
EB	0%	0.89
WB	1%	0.85
NB	1%	0.97
SB	1%	0.89
TOTAL	1%	0.98

Peak Hour Count Summaries

Peak Hour Interval Start	Orchard Ave				Carlos Bee Blvd				Mission Blvd				Mission Blvd				15-min Total	Rolling Hour Total	
	Eastbound		Westbound		Northbound		Southbound		Northbound		Southbound								
	UT	LT	TH	RT	UT	LT	TH	RT	UT	LT	TH	RT	UT	LT	TH	RT			
4:30 PM	0	37	78	18	0	40	81	68	1	9	300	65	12	63	270	44	1,086	0	
4:45 PM	0	31	69	12	0	52	73	74	3	15	307	63	10	55	258	41	1,063	0	
5:00 PM	0	28	89	16	0	39	69	45	6	12	284	63	8	40	310	45	1,054	0	
5:15 PM	0	26	57	13	0	46	50	39	0	15	301	75	13	59	330	50	1,074	4,277	
Pk Hr	All	0	122	293	59	0	177	273	226	10	51	1,192	266	43	217	1,168	180	4,277	
	HV	0	1	1	0	0	2	5	1	0	1	10	1	0	1	7	5	35	
	HV%	-	1%	0%	0%	-	1%	2%	0%	0%	2%	1%	0%	0%	0%	1%	3%	1%	

Note: For complete count summary (all intervals), see following pages.

** Heavy Vehicle Classifications include FHWA Classes 4-13.

** Count Summaries include heavy vehicles, but exclude bicycles in overall count.

Interval Start	Heavy Vehicle Totals					Bicycles					Pedestrians (Crossing Leg)				
	EB	WB	NB	SB	Total	EB	WB	NB	SB	Total	E	W	N	S	Total
4:30 PM	1	3	0	5	9	0	0	0	0	0	0	2	2	0	4
4:45 PM	0	1	6	0	7	0	0	0	0	0	0	0	1	0	1
5:00 PM	0	4	1	5	10	0	0	0	0	0	0	0	2	0	2
5:15 PM	1	0	5	3	9	0	0	0	0	0	0	0	3	0	3
Peak Hour	2	8	12	13	35	0	0	0	0	0	0	2	8	0	10

Count Summaries - All Vehicles																			
Interval Start	Orchard Ave				Carlos Bee Blvd				Mission Blvd				Mission Blvd				15-min Total	Rolling Hour Total	
	Eastbound				Westbound				Northbound				Southbound						
	UT	LT	TH	RT	UT	LT	TH	RT	UT	LT	TH	RT	UT	LT	TH	RT			
3:00 PM	0	25	58	13	0	35	51	48	2	17	271	36	9	54	287	40	946	0	
3:15 PM	0	23	52	14	0	52	70	88	8	20	302	46	9	58	257	39	1,038	0	
3:30 PM	0	19	48	14	0	43	55	49	1	12	291	61	12	48	257	36	946	0	
3:45 PM	0	26	50	20	0	46	59	48	6	20	320	72	10	45	269	31	1,022	3,952	
4:00 PM	0	25	72	14	0	32	56	40	4	12	294	58	12	41	293	34	987	3,993	
4:15 PM	0	26	61	5	0	35	47	44	4	17	330	70	10	58	296	34	1,037	3,992	
4:30 PM	0	37	78	18	0	40	81	68	1	9	300	65	12	63	270	44	1,086	4,132	
4:45 PM	0	31	69	12	0	52	73	74	3	15	307	63	10	55	258	41	1,063	4,173	
5:00 PM	0	28	89	16	0	39	69	45	6	12	284	63	8	40	310	45	1,054	4,240	
5:15 PM	0	26	57	13	0	46	50	39	0	15	301	75	13	59	330	50	1,074	4,277	
5:30 PM	0	22	58	11	0	40	59	41	6	19	309	69	11	63	292	46	1,046	4,237	
5:45 PM	0	20	64	14	0	38	52	48	2	11	260	74	7	60	244	34	928	4,102	
6:00 PM	0	18	59	12	0	42	46	47	0	21	319	73	5	44	273	39	998	4,046	
6:15 PM	0	21	78	7	0	16	35	35	4	21	304	65	4	54	208	62	914	3,886	
6:30 PM	0	23	59	5	0	35	40	52	2	11	219	78	13	51	212	33	833	3,673	
6:45 PM	0	16	60	14	0	42	34	37	1	10	232	62	10	44	216	26	804	3,549	
Count Total	0	386	1,012	202	0	633	877	803	50	242	4,643	1,030	155	837	4,272	634	15,776		
Pk Hr	All	0	122	293	59	0	177	273	226	10	51	1,192	266	43	217	1,168	180	4,277	
	HV	0	1	1	0	0	2	5	1	0	1	10	1	0	1	7	5	35	
	HV%	-	1%	0%	0%	-	1%	2%	0%	0%	2%	1%	0%	0%	0%	1%	3%	1%	

Interval Start	Heavy Vehicle Totals					Bicycles					Pedestrians (Crossing Leg)				
	EB	WB	NB	SB	Total	EB	WB	NB	SB	Total	E	W	N	S	Total
3:00 PM	0	0	6	10	16	0	0	0	0	0	0	7	2	0	9
3:15 PM	0	2	3	7	12	0	0	0	0	0	0	9	3	0	12
3:30 PM	0	3	8	7	18	0	0	0	0	0	0	4	5	0	9
3:45 PM	1	3	4	11	19	0	0	0	0	0	0	1	2	0	3
4:00 PM	0	2	7	7	16	0	0	0	0	0	0	0	2	0	2
4:15 PM	0	4	5	4	13	0	0	0	0	0	0	2	2	0	4
4:30 PM	1	3	0	5	9	0	0	0	0	0	0	2	2	0	4
4:45 PM	0	1	6	0	7	0	0	0	0	0	0	0	1	0	1
5:00 PM	0	4	1	5	10	0	0	0	0	0	0	0	2	0	2
5:15 PM	1	0	5	3	9	0	0	0	0	0	0	0	3	0	3
5:30 PM	0	1	1	4	6	0	0	0	0	0	0	0	1	1	2
5:45 PM	0	2	6	2	10	0	0	0	0	0	0	0	0	0	0
6:00 PM	0	0	2	2	4	0	0	0	0	0	1	0	0	0	1
6:15 PM	0	1	1	3	5	0	0	0	0	0	0	0	0	0	0
6:30 PM	0	0	2	5	7	0	0	0	0	0	0	0	0	0	0
6:45 PM	0	0	1	1	2	0	0	0	0	0	0	0	0	0	0
Count Total	3	26	58	76	163	0	0	0	0	0	1	25	25	1	52
Peak Hour	2	8	12	13	35	0	0	0	0	0	0	2	8	0	10

Count Summaries - Heavy Vehicles																		
Interval Start	Orchard Ave				Carlos Bee Blvd				Mission Blvd				Mission Blvd				15-min Total	Rolling Hour Total
	Eastbound				Westbound				Northbound				Southbound					
	UT	LT	TH	RT	UT	LT	TH	RT	UT	LT	TH	RT	UT	LT	TH	RT		
3:00 PM	0	0	0	0	0	0	0	0	0	3	3	0	0	0	9	1	16	0
3:15 PM	0	0	0	0	0	0	1	1	0	0	3	0	0	0	6	1	12	0
3:30 PM	0	0	0	0	0	2	1	0	0	0	7	1	0	1	5	1	18	0
3:45 PM	0	0	0	1	0	1	2	0	0	1	2	1	0	0	10	1	19	65
4:00 PM	0	0	0	0	0	0	0	2	0	0	5	2	0	0	7	0	16	65
4:15 PM	0	0	0	0	0	0	4	0	0	0	4	1	0	0	4	0	13	66
4:30 PM	0	1	0	0	0	0	3	0	0	0	0	0	0	1	2	2	9	57
4:45 PM	0	0	0	0	0	1	0	0	0	1	4	1	0	0	0	0	7	45
5:00 PM	0	0	0	0	0	1	2	1	0	0	1	0	0	0	3	2	10	39
5:15 PM	0	0	1	0	0	0	0	0	0	0	5	0	0	0	2	1	9	35
5:30 PM	0	0	0	0	0	0	1	0	0	0	1	0	0	0	2	2	6	32
5:45 PM	0	0	0	0	0	1	1	0	0	0	6	0	0	0	1	1	10	35
6:00 PM	0	0	0	0	0	0	0	0	0	1	1	0	0	0	2	0	4	29
6:15 PM	0	0	0	0	0	1	0	0	0	0	1	0	0	0	3	0	5	25
6:30 PM	0	0	0	0	0	0	0	0	0	1	1	0	0	0	4	1	7	26
6:45 PM	0	0	0	0	0	0	0	0	0	0	1	0	0	0	0	1	2	18
Count Total	0	1	1	1	0	7	15	4	0	7	45	6	0	2	60	14	163	
Pk Hr Heavy	0	1	1	0	0	2	5	1	0	1	10	1	0	1	7	5	35	
Count Summaries - Bikes																		
Interval Start	Orchard Ave				Carlos Bee Blvd				Mission Blvd				Mission Blvd				15-min Total	Rolling Hour Total
	Eastbound				Westbound				Northbound				Southbound					
	UT	LT	TH	RT	UT	LT	TH	RT	UT	LT	TH	RT	UT	LT	TH	RT		
3:00 PM	0	0	0	0	0	0	0	0	0	0	0	0	0	0	0	0	0	0
3:15 PM	0	0	0	0	0	0	0	0	0	0	0	0	0	0	0	0	0	0
3:30 PM	0	0	0	0	0	0	0	0	0	0	0	0	0	0	0	0	0	0
3:45 PM	0	0	0	0	0	0	0	0	0	0	0	0	0	0	0	0	0	0
4:00 PM	0	0	0	0	0	0	0	0	0	0	0	0	0	0	0	0	0	0
4:15 PM	0	0	0	0	0	0	0	0	0	0	0	0	0	0	0	0	0	0
4:30 PM	0	0	0	0	0	0	0	0	0	0	0	0	0	0	0	0	0	0
4:45 PM	0	0	0	0	0	0	0	0	0	0	0	0	0	0	0	0	0	0
5:00 PM	0	0	0	0	0	0	0	0	0	0	0	0	0	0	0	0	0	0
5:15 PM	0	0	0	0	0	0	0	0	0	0	0	0	0	0	0	0	0	0
5:30 PM	0	0	0	0	0	0	0	0	0	0	0	0	0	0	0	0	0	0
5:45 PM	0	0	0	0	0	0	0	0	0	0	0	0	0	0	0	0	0	0
6:00 PM	0	0	0	0	0	0	0	0	0	0	0	0	0	0	0	0	0	0
6:15 PM	0	0	0	0	0	0	0	0	0	0	0	0	0	0	0	0	0	0
6:30 PM	0	0	0	0	0	0	0	0	0	0	0	0	0	0	0	0	0	0
6:45 PM	0	0	0	0	0	0	0	0	0	0	0	0	0	0	0	0	0	0
Count Total	0	0	0	0	0	0	0	0	0	0	0	0	0	0	0	0	0	
Pk Hr Bike	0	0	0	0	0	0	0	0	0	0	0	0	0	0	0	0	0	

Carlos Bee Boulevard Queue Length Observations

Approximate Queue length (in feet)

	1/16/2025	3/6/2025	3/19/2025
7:50 AM	440	640	190
7:55 AM	290	510	190
8:00 AM	715	635	660
8:05 AM	625	700	470
8:10 AM	640	455	350
8:15 AM	375	390	650
8:20 AM	735	135	245
8:25 AM	550	590	320

Summary

Avg	546	507	384
50th (median)	588	550	335
95th	728	679	657